

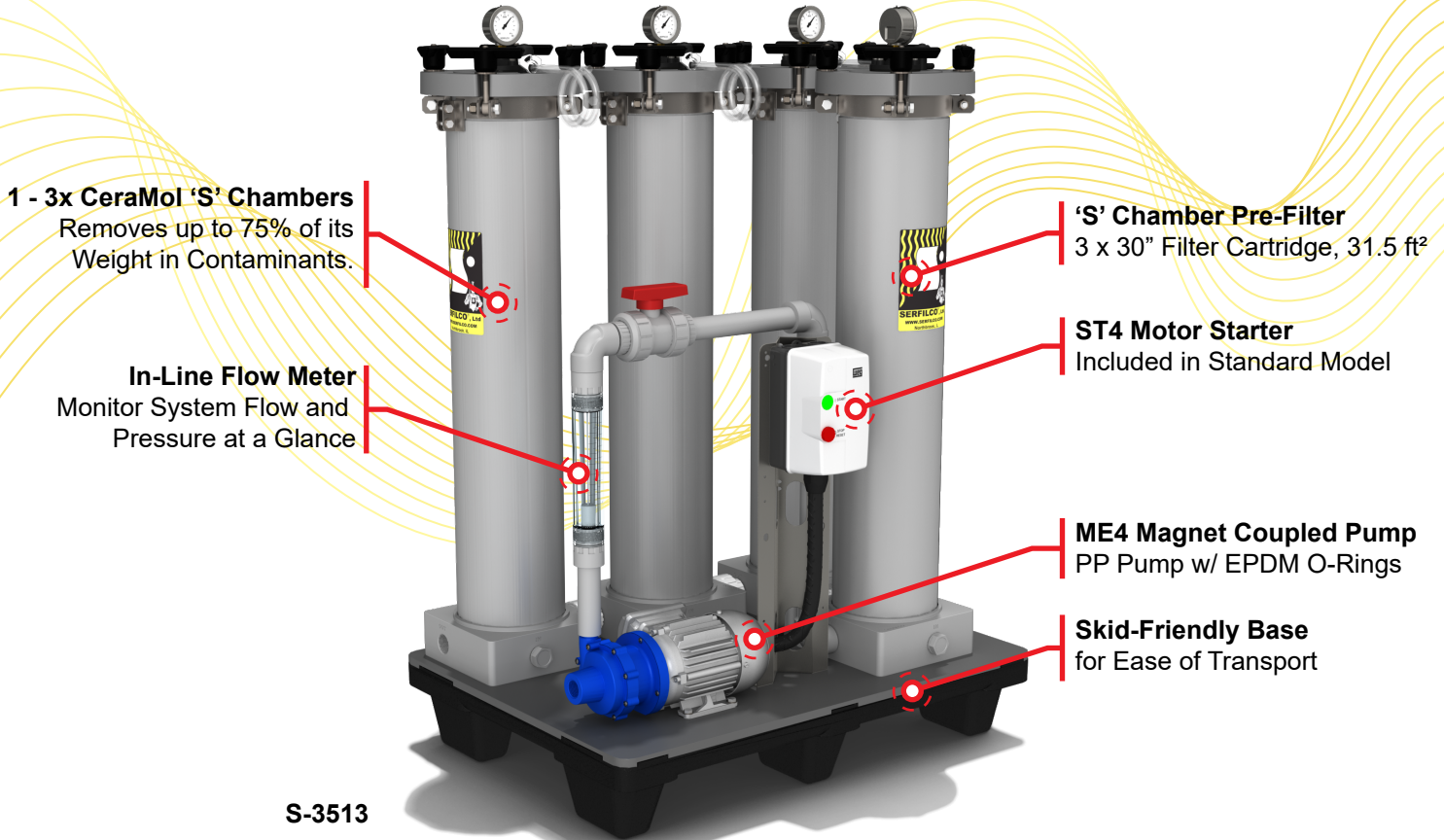

SerPure - 'S' | CeraMol FILTRATION SYSTEMS



SerPure SYSTEM INFORMATION*

SYSTEM NUMBER**	QTY CeraMol CHAMBERS	CeraMol MEDIA (WEIGHT)	TARGET FLOW RATE	MATERIAL (CHAMBER x PUMP)	PUMP HP	INLET x OUTLET
S-3511	1	.27ft ³ (7 lbs)	8 gpm	CPVC / EPDM	1/4 HP (1PH)	1 NPT
S-3512	2	.54ft ³ (14 lbs)		x		x
S-3513	3	.81ft ³ (21 lbs)		PP / EPDM PUMP		1 NPT

* Review Optional Equipment on Page 2.

** See R-292 for G-Canister System.

CeraMol MEDIA

PART NUMBER	DESCRIPTION	QUANTITY
99-8555-A	Aluminum Removal Media	100lb Drum
99-8555-C	Recalcitrant COD & Organics Removal Media	100lb Drum
99-8555-F	Iron Removal Media	100lb Drum
99-8555-M	Metal Removal Media (Cu, Ni, Cr, Zn, Sn, Pb, Cd)	100lb Drum
99-8555-S	Acid Removal Media	100lb Drum
99-8555-CR	Chrome-3 & Chrome-6	100lb Drum
99-8555-AN	Anion Removal - Sulphates, Phosphates etc.	100lb Drum
99-8555-SR	Silica Removal	100lb Drum



SerPure - 'S' | FILTRATION SYSTEMS

PREFILTER MEDIA

DESCRIPTION	PART NUMBER	MICRON	Sq. Ft**
REPLACEMENT CARTRIDGES	SF-25U30U-15	25 µm	10.50
	SF-50U30U-15	50 µm	10.50
	SF-99U30U-15	100 µm	10.50
CANISTER CARTRIDGE	SF-050U4U-60*	15 µm	1.40

* Trap Filter Inside Canister(s)
** Per one cartridge (3 per chamber)

OPTIONAL EQUIPMENT

PART NUMBER	DESCRIPTION
Add '-V' to Sys. No. P-88-2779-2	FKM O-Rings REPLACEMENT CANISTER

DIMENSIONAL INFORMATION (SerPure 'S')

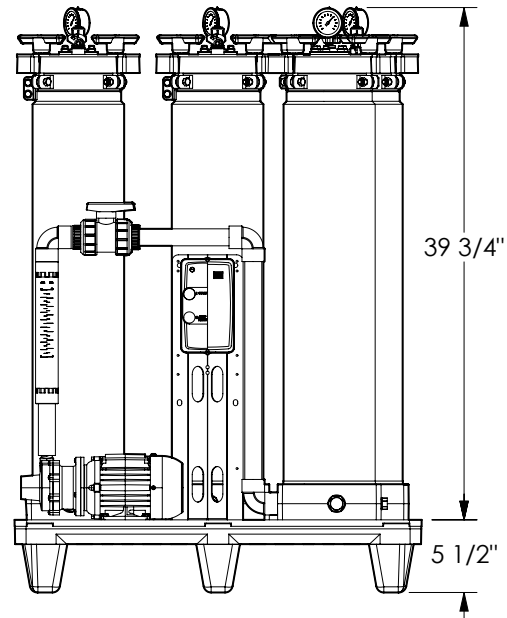
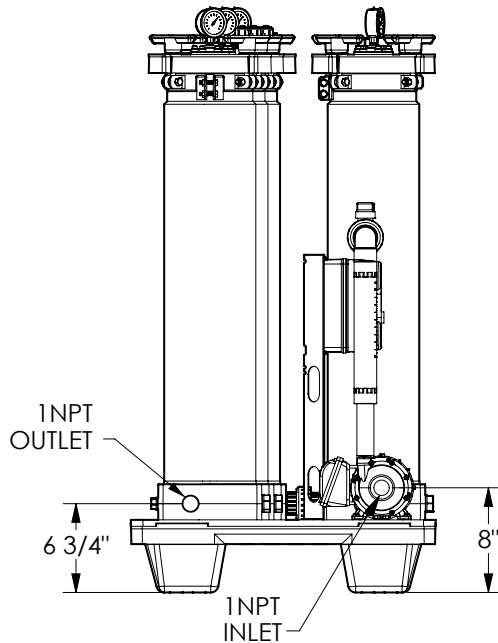
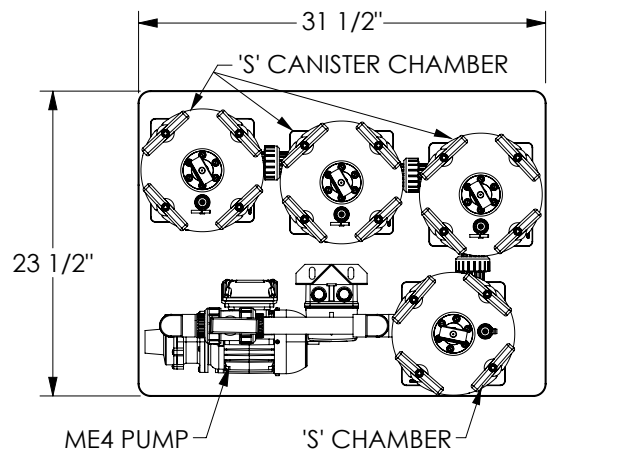

SERFILCO®

Chemical resistant pumps & filters engineered for industry

2900 MacArthur Blvd.
Northbrook, IL. 60062-2005 U.S.A (800) 323-5431
E-Mail: sales@serfilco.com (847) 509-2900
Web: www.serfilco.com (847) 559-1141

© 2024 SERFILCO Ltd, All Rights Reserved.

F.O.B. Northbrook, Illinois