



# AUTOMATIC GRAVITY FILTRATION SYSTEMS SERIES 'S'

(Manufactured prior to 1998)

PARTS LIST  
P-7900B  
NOV. 1998

Refers to Bulletin F-701, Operation  
and Service Guide O-0280.

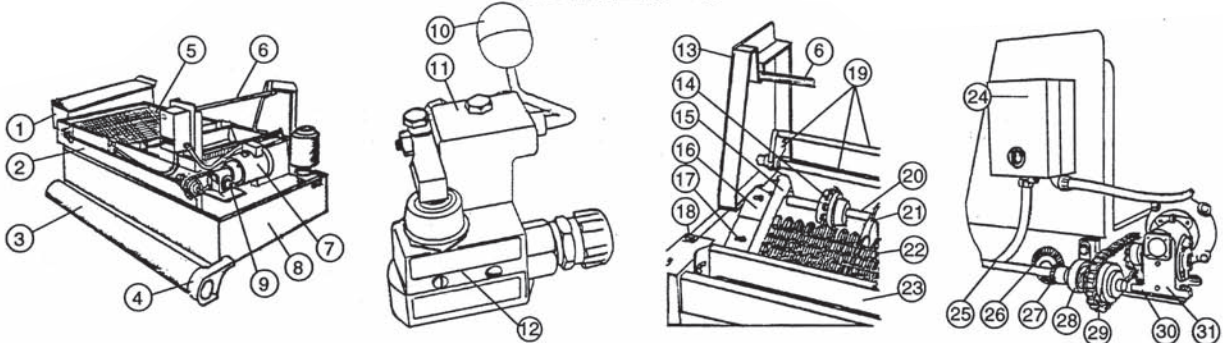

ITEM	DESCRIPTION	MODELS	PART NUMBERS				
			DF-4	DF-8	DF-11	DF-15	DF-17
1	Sludge box - carbon steel - w/epoxy coating (optional) - polypropylene		- - 49-0735	49-0236 49-0236 A -	49-0236 49-0236 A -	49-0236 49-0236 A -	49-0236 49-0236 A -
2	Frame - carbon steel - w/epoxy coating (optional)		49-0611 49-0522	49-0612 49-0612 A	49-0613 49-0613 A	49-0614 49-0614 A	49-0615 49-0615 A
3	Drive shaft guard - carbon steel		-	49-0554	49-0555	49-0556	49-0557
4	Chain guard - carbon steel		49-0622	49-0623	49-0623	49-0623	49-0624
5	Conveyor belt - galvanized - 304 stainless steel (optional)		49-0626 49-0001	49-0627 49-0004	49-0628 49-0007	49-0629 49-0010	49-0630 49-0013
6	Fabric tube holder - carbon steel		49-0523	49-0526	49-0526	49-0526	49-0526
7	Motor - 1/3 HP - 115/1/60 - 1/2 HP - 115/1/60 - 3/4 HP - 115/1/60		49-0529 - -	49-0529 - -	49-0529 - -	49-0529 - -	49-0529 - -
8	Filter tank - carbon steel - w/epoxy coating (optional)		49-0637 49-0637 A	49-0638 49-0638 A	49-0639 49-0639 A	49-0640 49-0640 A	49-0641 49-0641 A
9	Speed reducer - carbon steel		49-0516	49-0648	49-0648	49-0648	49-0649
10	Float - polypropylene		49-0505	49-0505	49-0505	49-0505	49-0505
11	Float rod assembly		49-0506	49-0506	49-0506	49-0506	49-0506
12	Micro switch		49-0504	49-0504	49-0504	49-0504	49-0504
13	Fabric roll bracket - carbon steel		49-0514	49-0598	49-0598	49-0598	49-0598
14	Conveyor sprocket - carbon steel 4" - carbon steel 6"		49-0520 -	49-0520 -	49-0520 -	49-0520 -	49-0520 -
15	Seal strips - PVC		49-0500	49-0500	49-0651	49-0652	49-0653
16	Seal hold-down plate		49-0513	49-0513	49-0513	49-0513	49-0513
17	Hex head bolt, 5/16"-18 x 3/4" - stainless steel Flat washer, 5/16" size - stainless steel		11-0315 11-0122	11-0315 11-0122	11-0315 11-0122	11-0315 11-0122	11-0315 11-0122
18	Wing nut, 5/16"-18 - stainless steel		11-0514	11-0514	11-0514	11-0514	11-0514
19	Fabric hold-down bar assembly		49-0518	49-0532	49-0532	49-0532	49-0532
20	Conveyor shaft		49-0519	49-0660	49-0660	49-0660	49-0660
21	Nylon wear strip		49-0521	49-0588	49-0589	49-0590	49-0591
22	Conveyor support ribs - carbon steel - w/epoxy coating (optional)		49-0734 49-0734 A	49-0664 49-0664 A	49-0664 49-0664 A	49-0664 49-0664 A	49-0664 49-0664 A
23	Diffuser tray - carbon steel - w/epoxy coating (optional)		49-0539 49-0539 A	49-0540 49-0540 A	49-0540 49-0540 A	49-0540 49-0540 A	49-0540 49-0540 A
24	Motor starter - magnetic NEMA 1		49-0667	49-0667	49-0667	49-0667	49-0667
25	Drive shaft - carbon steel		-	49-0668	49-0669	49-0670	49-0671
26	Conveyor shaft bevel gear		-	49-0511	49-0511	49-0511	49-0512
27	Line shaft bevel pinion		-	49-0509	49-0509	49-0509	49-0510
28	Pillow block bearing		-	49-0678	49-0678	49-0678	49-0679
29	Chain		49-0681	49-0682	49-0682	49-0682	49-0683
30	Torque limiter		-	49-0684	49-0684	49-0684	49-0685
31	Reducer sprocket - carbon steel		49-0687	49-0688	49-0688	49-0688	49-0689
32	Micro switch cover (not shown)		49-0517	49-0517	49-0517	49-0517	49-0517
33	Conveyor shaft bearing - carbon steel (not shown)		49-0691	49-0691	49-0691	49-0691	49-0691
34	Conveyor pulley 4" (2 req'd) (not shown) 6" (5 req'd) (not shown)		49-0692 -	- -	- -	- -	- -
35	Disposa-Fabric - see operating instructions O-280 for fabric selection						

