

SERFILCO® TITAN FILTRATION SYSTEMS FOR POLISHING TREATED WASTE

OPERATION AND SERVICE GUIDE
O-3090A
MAY 2002

Model	W400
--------------	-------------

Refer to Bulletin F-455.

Model W Titan Systems are designed specifically for aqueous and treated waste applications. The system polishes waste water by recirculating overflow from a clarifier, capturing low ppm suspended solids, and satisfying regulatory requirements. With proper recirculation, 0.5 ppm can be achieved. In fact, polished water can be reused in non-critical rinses.

! Model W Titan Systems are not designed for use with flammable or explosive products.

HANDLING

A forklift should be used for handling Titan systems. If the entire system is on a base, use a forklift making sure the forks are placed under the base, not under the chamber. When a chamber is not attached to the base, use the ears/handles that are welded on top of the chamber for handling. **DO NOT USE THE COVER HOLD DOWN BRACKETS FOR THIS PURPOSE.** Place straps or chains of sufficient strength in each ear and use a forklift to lift the unit to prevent damage to the chamber. Use care to prevent the chamber from swaying.

PLUMBING

Plumb the overflow from your clarifier to the end of a recirculation tank directly opposite the end where the Titan suction feed line is connected. Locate the Titan waste system as close to a recirculation tank as possible. The system's pump is not self-priming. A flooded suction is required to maintain proper prime for the system to function properly. It is strongly suggested that elbows not be used on the suction supply line for the pump. The total flow rate will be decreased by 2.5 gallons per hour for every 90° elbow on the suction side. Do not place an elbow within 10 pipe diameters of the suction supply line of the unit. If elbow use is unavoidable, or to keep the suction intake piping run as short as possible, the pipe size for the suction intake will have to be increased to compensate for restriction and friction loss. Do not decrease the pipe size of the suction or the discharge. The discharge return line should come up and over the opposite side of the recirculation tank from where the suction intake is located and be positioned just above the solution level of the recirculation tank. Increasing the final 4 feet of the discharge pipe by 1 inch will help minimize splashing. It is recommended to use PVC schedule-80 slip joint glued fittings for plumbing the Titan to and from the recirculation tank and to waste treatment. It is suggested plumbing the discharge for the backflush to a holding tank, prior to pH adjustment, to avoid surging your waste treatment system.

The system's pump is constructed of CPVC with a double mechanical seal that requires a constant, low volume flow of fresh water. For optimum seal performance and longevity, an incoming flow of 4 gallons per hour at 15 PSI above pump's operating pressure must be provided to the seal chamber.

Please feel free to contact SERFILCO's technical support department to review your plumbing layout or other areas of concern prior to installation.

ELECTRICAL

The 3-phase filter units are factory wired to your specific primary voltage. Install a 3-phase line to the control panel and connect the power to the top of the main disconnect switch. The installation of an external fused disconnect switch near the unit is recommended. No further wiring is required. The pump and all valves are individually fused inside the control panel.

Rotation for the system's pump motor must be correct. A rotation arrow affixed to the motor indicates proper rotation. View the motor from the fan end and bump start the pump motor by pressing the center of the contactor located inside the control panel to verify correct rotation.

Should a cycle change be required, consult the factory. Any unauthorized change in the PLC program by other than SERFILCO service personnel will void the warranty.

AIR SUPPLY

A 1/2" air line, with a minimum of 50 PSI @ 30 CFM, needs to be installed and connected to the filter/regulator provided on the unit.

REGULATOR

Adjustment - Pull adjustment knob upward to unlock. Turn clockwise to increase and counterclockwise to decrease outlet pressure setting. To reduce pressure, first reduce to a pressure less than desired, then increase to the desired outlet pressure. Push adjustment knob downward to re-lock.

Servicing

1. Keep accumulated water below baffle on the main filter/regulator by observing level through sight glass located on the filter housing. Open valve on bottom of housing to drain.
2. Replace filter element when dirty.

MEDIA

The TITAN filter is shipped without media in the chamber. On some models, coarse media will be installed.

Remove the cover of the filter chamber and cover laterals with water. Slowly add _____ lbs. of coarse media followed by _____ lbs. fine media. Level off the media and replace and secure the filter chamber cover.

START-UP

Media will always contain fine particles and should be manually backflushed to waste treatment prior to initial start-up or when changing media.

1. Fill the recirculation tank 3/4 full or more with fresh clean water.
2. If installed, open all manual valves. The suction feed line for the pump should become flooded.
3. Turn the air supply on and adjust main filter/regulator pressure to 25 PSI on all models.
4. Turn on the water supply line for the Dri-Stop pump protector and adjust to a rate of 4 GPH or greater @ 15 PSI above discharge pressure.
5. Turn the main disconnect switch ON.

6. Turn the power switch on.
7. Turn the mode switch to hand position.
 - a. Air agitation will come on for 1 minute.
 - b. After a 30 second pause, backflushing will begin.
 - c. Manually time the backflush cycle for three minutes, then immediately turn the mode switch to off.
 - d. Turn the overflow from the clarifier on to start feeding the recirculation tank.

When the recirculation tank is half full, turn the mode switch to the auto position. The Titan will begin to recirculate. As the contaminants build up in the filter media and slow the flow rate down to the low setting point, the unit will go into an automatic backflush cycle. The red light marked relay-1 on the flow meter will appear steady for 2 minutes before this takes place.

FLOW METER

The low flow set point has been pre-calibrated for typical operation at the factory. If the settings need to be adjusted, refer to the flow monitor instructions included in your booklet on how to enter the calibrating menu to adjust the low flow setting.

VALVES

⚠ CAUTION: Before any maintenance is performed and to prevent ignition of hazardous atmospheres and reduce the risk of electrical shock, never remove actuator covers while circuits are live.

If a fault light/horn alarm occurs from an out-of-position valve, consult factory for proper procedure to correct the problem.

Valves are manufactured with factory lubricated grease

in the gear case. In most cases this lubricant should never have to be replenished.

SHUTDOWN

Turn the mode switch to the off position. All of the electric valves will turn to their proper positions. After 10 seconds, turn the power switch to off. It is suggested that all manual valves be turned to their closed positions. This will assure no solution loss due to a siphoning action.

The Titan filter has a power failure circuit built in. If you experience a power failure, the filter unit will not restart automatically. To restart the system, turn the mode switch to the off position and then back to auto.

Little or no maintenance is required on this filter unit. However, the unit should be periodically checked for plumbing leaks, air leaks, etc. The control panel door must be locked at all times.

MANUAL BACKFLUSHING PROCEDURE

⚠ CAUTION: Do not use the start-up procedure to perform a manual backflush.

Turn the mode switch to hand position.

- a. Air agitation will come on for 1 minute.
- b. After a 30 second pause, backflushing will begin.
- c. Manually time the backflush cycle for 3 minutes, then immediately turn the mode switch to off. Turn the mode switch back to the auto position to return to filtration.

MAINTENANCE

When and if cleaning of the tank is required it must be done in accordance with the regulation in force in the country and the product used.

POLISH FILTER TROUBLESHOOTING	
PROBLEM	SOLUTION
1. Pump will not come on:	<ol style="list-style-type: none"> a. Check 3 phase fuses. b. Verify water is flowing through the Dri-Stop at a minimum of 4 GPH. One of the valves is out of position, which is the only cause for the fault alarm to come on.
2. Fault light comes on:	
3. Flow rate not returning to the original value after automatic backflush:	<ol style="list-style-type: none"> a. Media may be over-contaminated. Proceed with a manual backflush. b. If manually backflushing does not correct the problem, proceed with manual hypochlorite cleaning procedure. With frequent clarifier regurgitations, the above treatment may have to be done weekly. (See procedure for hypochlorite cleaning) c. Plumbing may have scale build-up due to water hardness. Acidify the recirculation tank with inhibited muriatic acid and allow the filter system to recirculate for several hours. Proceed with a manual backflush. d. Media bed may be over-contaminated with flocculation polymer. Drain the chamber and skim off approximately one inch of media. Polymer will usually not penetrate the media beyond this point.
4. Filter backflushing too frequently	<ol style="list-style-type: none"> a. Too many solids overflowing from the clarifier. Drain the recirculation tank. Media may have become over-contaminated from reverse direction with dirty backflush. b. Do not surge the clarifier. c. Check polymer adds.
5. Losing media:	Broken or cracked plumbing inside chamber. Remove media and inspect. Repair as necessary.

FUNCTION	VALVE 1	VALVE 2	VALVE 3	VALVE 4
RECIRC.	closed	open	open	closed
BACKFLUSH	open	closed	closed	open
SHUTDOWN	open	closed	open	closed

POLISH FILTER FLOW DRAWING WITH MANUAL CLEANING

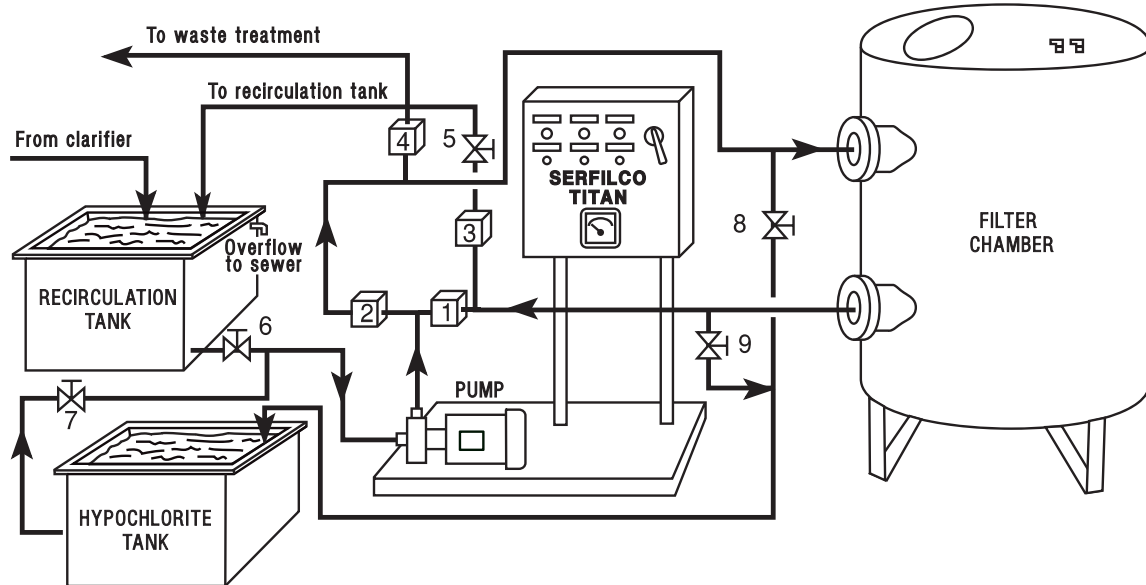

HYPOCHLORITE (MANUAL) CLEANING PROCEDURE

1. Leave the POWER switch ON and turn the MODE switch to OFF. This will leave valves #1 and 3 open and #2 and 4 closed.
 2. Open valve #5 and close all others.
 3. Open the 1/2" air valve. This will pressurize the filter chamber (25 PSI) and purge the water back to the recirculation tank.
 4. When large volumes of air appear in the recirculation tank, turn the 1/2" air valve off.
 5. Open valves #7 and 8.
 6. Close valves #5, 6 and 9.
 7. Turn the manual clean switch ON to start the pump. This will allow the sodium hypochlorite to recirculate through the media in a reverse direction. Allow this to run for 10 to 12 hours.
 8. Close valves #5, 6, 7 and 8.
 9. Open valve #9.
 10. Open the 1/2" air valve. This will purge the filter chamber of cleaner solution. The filter will now need a backflush to rid itself of cleaner solution.
 11. Open valves #5 and 6.
 12. Close valves #7, 8 and 9.
 13. You may now proceed with a manual backflush. These valve positions will also remain with the AUTO cycle.
- NOTE: To drain your cleaner tank, simply close valves #5, 6, 8 and 9. Open valve #7 and turn the MODE switch to HAND.

SERFILCO TITAN FILTER

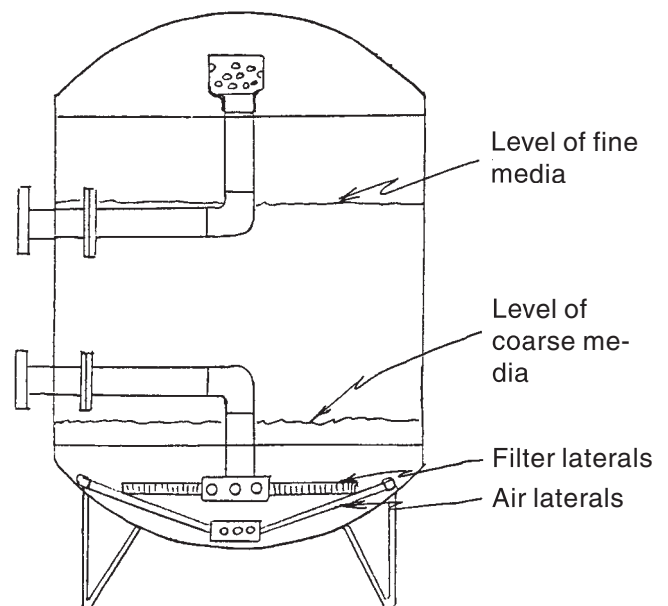

WARRANTY

SERFILCO warrants products* of its own manufacture will be free from defects in raw materials and manufacture under normal use and service for a period of not more than one year after date of shipment. **SERFILCO's** obligation under this warranty is limited to repair or replacement of its products which shall be returned to **SERFILCO's** headquarters, Northbrook, Illinois, U.S.A., with all transportation and associated charges prepaid, and which examination shall disclose to **SERFILCO's** satisfaction to have been thus defective at time of shipment, provided that **SERFILCO** had received immediate written notice upon discovery of such alleged defect and the alleged defective products shall have returned to **SERFILCO** not later than 30 days after **SERFILCO** has issued a Return Authorization Number. This warranty shall not apply to any of the products which shall have been used other than for their intended use, nor to any of the products, the composition of which shall have been changed in any way, nor to any of the products which have been subject to adverse storage conditions, misuse, negligence or accident.

SERFILCO shall not be held liable for damage or delays caused by defective raw materials and manufacture, nor shall **SERFILCO** be liable for consequential damages in cases of failure to meet the conditions of warranty. The full liability of **SERFILCO** under this clause is the repair or replacement of defective parts, at its discretion.

The customer is responsible for the proper installation and operation of the equipment. A factory representative is available at start-up at cost of travel expenses plus charge per diem. Consult Sales Department.

* Products such as filter cartridges do not normally last one year and may require frequent replacement. In addition, certain components such as mechanical seals, springs, "O"-rings, hose, ceramic liners, impeller magnet assemblies, diaphragms, etc. may be subject to wear and, therefore, wear should not be construed as evidence of the existence of a defect, and as such will not be honored in a warranty claim, nor should it be inferred that items such as these will last a year without occasional, or even frequent, replacement depending upon the severity of the application. Items not of **SERFILCO's** manufacture, such as motors, carry similar warranties by the manufacturer, and can often be serviced through local authorized repair center or handled through our office.

This express warranty is given in lieu of all other warranties. All other warranties and, specifically, the implied warranties of merchantability and fitness for particular purposes, are excluded. No person, agent or representative of **SERFILCO** is authorized to give any other warranties on **SERFILCO's** behalf or to assume for it any other liability in connection with any of the products.

! WARNING — Any modification, alteration or other changes to **SERFILCO's** products will void any warranty and could cause damage or injury to the user of the products.

RETURN AUTHORIZATION POLICY

Inasmuch as **SERFILCO, Ltd.** produces products which are in industrial / commercial applications wherein these products come in intimate contact with chemicals, solvents, or other substances which may be classified as hazardous substances, and there exists federal, state and local legislation defining responsibilities and liabilities with regard to the generation, transportation, storage, and disposal of such substances, and that these same products may be returned to **SERFILCO** for service or other reasons after coming in contact with such substances, the following applies to return of used equipment.

USER RESPONSIBILITY

It is assumed that the user of **SERFILCO, Ltd.** products is in compliance with all aspects of legislation dealing with hazardous substances. To that end, the procedures for the legal transportation and disposal of such substances are the sole responsibility and liability of the user. Prior to any return of used merchandise the user shall:

1. Contact **SERFILCO, Ltd.** to obtain a Return Authorization Number and specific shipping instructions.
2. Thoroughly cleanse the merchandise to be returned so that no detectable residue of any substances remains on any surface.
3. Prepare a legal shipping container suitable for the return of this merchandise to **SERFILCO, Ltd.** The shipping container must have the Return Authorization Number clearly and legibly imprinted above the shipping label.
4. The user is responsible for shipping the merchandise to **SERFILCO, Ltd.** and for the freight charges in both directions.
5. PLEASE NOTE: In the presence of the delivering carrier, **SERFILCO** personnel will open and inspect all returned merchandise, and will refuse and return to shipper all merchandise not meeting these conditions.
6. Assume responsibility for the final disposition of any used merchandise i.e., reuse of a repaired or otherwise reusable product, or the legal disposal of a defective or otherwise unusable product.
7. Used filter media, carbon or ion-exchange resins may not be returned to **SERFILCO, Ltd.** and will be refused.
8. Samples for test will not be accepted. **SERFILCO** offers rental and test equipment for field testing, subject to the above conditions.

In the event that used merchandise is returned to **SERFILCO, Ltd.** without strict compliance to this policy, **SERFILCO** reserves the right to refuse receipt of such products. **SERFILCO** will direct that the carrier involved return same to sender in accordance with the above policy and procedure.

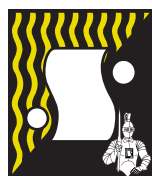

SERFILCO[®], LTD.

2900 MacArthur Blvd. 847-509-2900
Northbrook, IL 60062-2005 U.S.A. 800-323-5431
e-mail: sales@serfilco.com FAX: 847-559-1995
www.serfilco.com

SERFILCO TITAN WASTE MODELS 50, 100, 150, 200, 300

FUNCTION	VALVE 1		VALVE 2	VALVE 3
	A	B		
RECIRC.	closed	open	open	closed
BACKFLUSH	open	closed	closed	open
SHUTDOWN	open	closed	open	closed

POLISH FILTER FLOW SCHEMATIC with MANUAL CLEANING

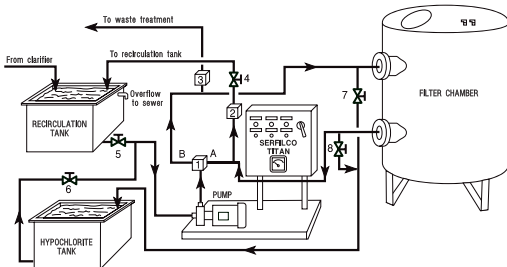

MANUAL CLEAN CYCLE PROCEDURE

1. Leave the POWER switch ON and turn the MODE switch to OFF. This will leave valves #1A and 2 open and #3 closed.
2. Open valve #4 and close all others.
3. Open the 1/2" air valve. This will pressurize the filter chamber (20 PSI) and purge the water back to the recirculation tank.
4. When solution appears to have stopped discharging from return line to the recirculation tank, turn the 1/2" air valve OFF.
5. Open valves #6 and 7.
6. Close valves #4, 5 and 8.
7. Turn the MANUAL clean switch ON to start the pump. This will allow the sodium hypochlorite to recirculate through the media in a reverse direction. Allow this to run for 10 to 12 hours.
8. Close valves #4, 5, 6 and 7.
9. Open valve #8.
10. Open the 1/2" air valve. This will purge the filter chamber of cleaner solution. The filter will now need a backflush to rid itself of cleaner solution.
11. Open valves #4 and 5.
12. Close valves #6, 7 and 8.
13. You may now proceed with a manual backflush. These valve positions will also remain with the AUTO cycle.

NOTE: To drain your cleaner tank, simply close valves #4, 5, 7 and 8. Open valve #6 and turn the mode switch to HAND.

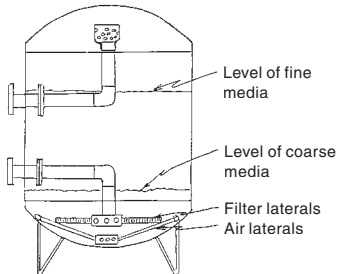

SERFILCO TITAN WASTE MODEL 400

FUNCTION	VALVE 1	VALVE 2	VALVE 3	VALVE 4
RECIRCULATE	closed	open	open	closed
BACKFLUSH	open	closed	closed	open
SHUTDOWN	open	closed	open	closed

WASTE FILTER FLOW SCHEMATIC with MANUAL CLEANING

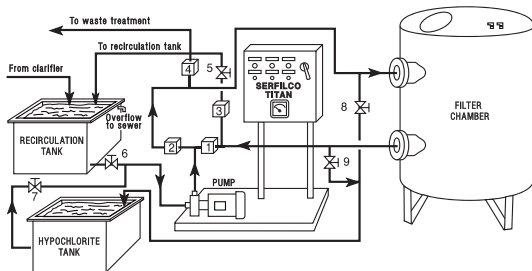

MANUAL CLEAN CYCLE PROCEDURE

1. Leave the POWER switch ON and turn the MODE switch to OFF. This will leave valves #1 and #3 open and #2 and #4 closed.
2. Open valve #5 and close all others.
3. Open the 1/2" air valve. This will pressurize the filter chamber (25 PSI) and purge the water back to the recirculation tank.
4. When large volumes of air appear in the recirculation tank, turn the 1/2" air valve OFF.
5. Open valves #7 and 8.
6. Close valves #5, 6 and 9.
7. Turn the MANUAL clean switch ON to start the pump. This will allow the sodium hypochlorite to recirculate through the media in a reverse direction. Allow this to run for 10 to 12 hours.
8. Close valves #5, 6, 7 and 8.
9. Open valve #9.
10. Open the 1/2" air valve. This will purge the filter chamber of cleaner solution. The filter will now need a backflush to rid itself of cleaner solution.
11. Open valves #5 and 6.
12. Close valves #7, 8 and 9.
13. You may now proceed with a manual backflush. These valve positions will also remain with the AUTO cycle.

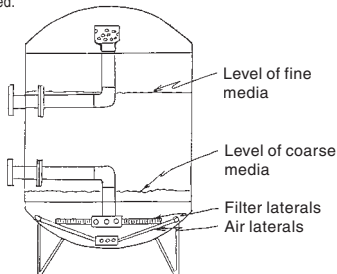

NOTE: To drain your cleaner tank, simply close valves #5, 6, 8 and 9. Open valve #7 and turn the mode switch to HAND.