

# AUTOMATIC PUMP CONTROL FOR FILTER PRESSES

OPERATION AND SERVICE GUIDE  
O-1455  
AUG. 1997

Refer to Bulletin F-705

## OPERATING PRINCIPLE

The multi-stage sludge feed concept is utilized to maximize the dewatering capabilities of the filter press. Through experimentation it has been determined that the best results for a metal hydroxide sludge have been obtained by filling the filter press in stages. The most effective method of filling the filter press is by using three separate inlet pressures. This can be accomplished by using an air diaphragm pump as the sludge pump.

Because the air diaphragm pump's volume and pumping pressure are related to the air pressure which operates it, this type of pump is best suited for the multi-stage feed application. By using three different regulators in combination with three solenoids and a control panel, the sludge pump can be controlled at three different operating pressures for varying lengths of time.

Stage one- is a low pressure stage which primarily fills the filter press cavities without forcing sludge into the weave of the cloth. By filling the press at low pressure the solids have a chance to coat the filter chambers evenly without blinding the cloths.

Stage two - is a moderate pressure stage. This stage allows the transition to a higher pumping pressure to occur without disturbing the still fragile coating of sludge which was deposited in stage one. During this stage the solids content within the filter cavities is brought to a thick, mud- like consistency. This type of sludge will withstand the high pressure pumping in stage three.

Stage three - is the final stage. During this stage the pumping pressure will be great enough to force the solids together. The pressure will drive the water from the filter cavities to the filtrate line (point of least resistance). Essentially, the pressure at which the pump is set will be the amount of force being exerted on the sludge. This force will drive 30 to 40 percent of the water from the sludge, making a material which began at a consistency similar to that of a wet sponge into a material resembling clay.

## APPROXIMATE OPERATING PARAMETERS

STAGE	TIME SETTING	PUMPING PRESSURE	SLUDGE CONSISTENCY
1	15 to 20 (min.)	20 PSIG	wet & spongy
2	45 to 60 (min.)	40 to 50 PSIG	thick mud
3	to end of cycle	80 to 100 PSIG	clay

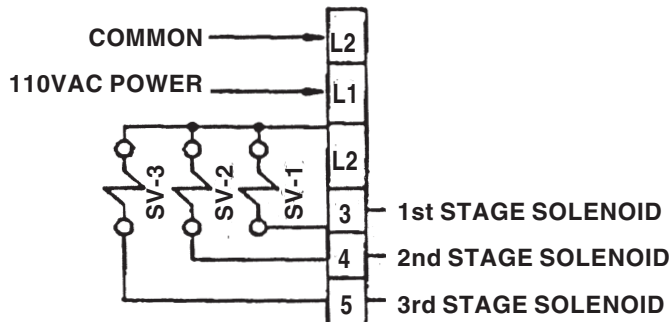
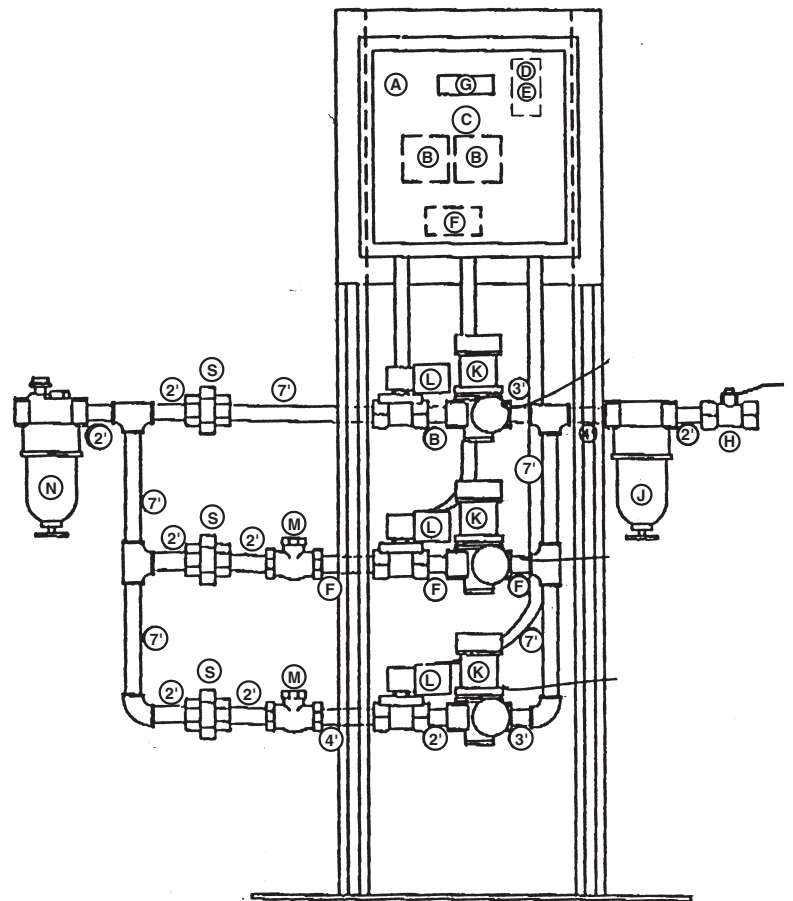

## TERMINAL STRIP

**OPTIONAL**

Also, for use in multiple clarifier layouts, a feed pump alternator has been incorporated to allow duplex processing of sludge. Upon reaching high pressure, a recycle timer will determine the run time of each pump at this high pressure stage.

RTR -T1 -Controls Pump 1  
RTR -T2-Controls Pump 2

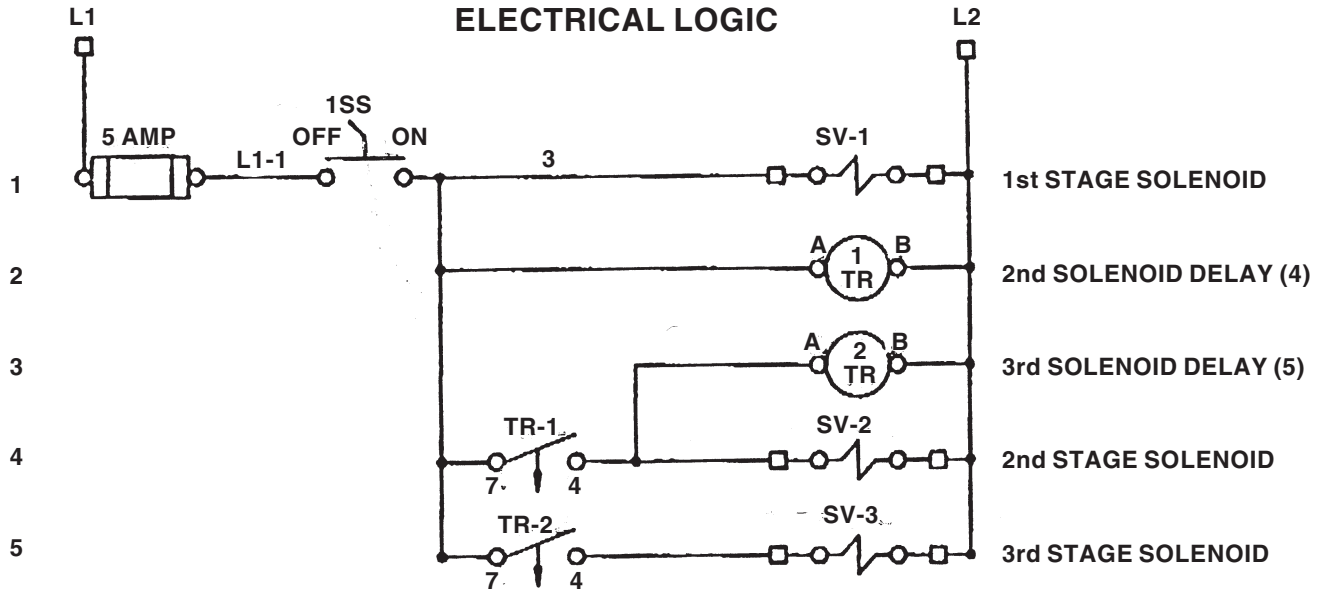

**BILL OF MATERIAL**

ITEM	QTY.	DESCRIPTION
A	1	NEMA 12 enclosure 12 x 12 x 6 (Hoffman) A-1212CH w/ back panel
B	2	ON delay timer (IDEC) RTE-BN2 w/SR 3B05 base
C	1	2 position switch (SQ D) KS-11 w/no contact block KA-2
D	1	Fuse block (1) pole, 110V (buss. 2807)
E	1	Fuse 10 AMP, 110V (KTK-10)
F	1	Terminal strip
G	1	Tag 1" x 3" black w/white lettering titled "FILTER PRESS PUMP"
H	1	1/2" Speedaire 5 x 715 hand valve
J	1	1/2" Norgren F12-400-A3TA airline filter
K	3	1/2" Norgren R12-400-RGLA regulator
L	3	1/2" Dayton 1A577 2-way NC solenoid valve w/ 6 x 543 120V coil
M	2	1/2" Speedaire 5 x 782 bronze check valve
N	1	1/2" Norgren L12-400-DPLA air lubricator
3	3	3" nipple
2	10	2" nipple
4	3	4" nipple
7	5	7" nipple
S	3	1/2" unions



**SERFILCO, LTD.**

2900 MacArthur Blvd. 847-509-2900  
 Northbrook, IL 60062-2005 U.S.A. 800-323-5431  
 e-mail: sales@serfilco.com FAX: 847-559-1995  
 www.serfilco.com