

PLASTIC SUMP PUMP MODEL 'OL75'

Refer to Bulletin P-310 and Parts List P-8975.

⚠ SAFETY PRECAUTIONS BEFORE STARTING PUMP

1. Read operating instructions and instructions supplied with chemicals to be used.
2. **Refer to Chemical Resistance Data Chart for compatibility of materials in pump with solution to be used.**
3. Note temperature and pressure limitations.
4. Personnel operating pump should always wear suitable protective clothing: face mask or goggles, apron, gloves.
5. All piping must be supported and aligned independently.
6. Always close valves slowly to avoid hydraulic shock.
7. Ensure that all fittings and connections are properly tightened.
8. Ground motor before connecting to electrical power supply. Failure to ground motor can cause severe or fatal electrical shock hazard. **DO NOT** ground to gas supply line.

⚠ BEFORE CHANGING APPLICATION OR PERFORMING MAINTENANCE

1. **Wear protective clothing as described in Item 4 above.**
2. Flush pump thoroughly with a neutralizing solution to prevent possible harm to personnel.
3. Shut off power to motor at disconnect switch.

IMPORTANT

1. The pump is constructed of CPVC, polypropylene or PVDF as ordered. Fasteners are stainless steel. Pump shaft is made from stainless steel and protected by a plastic sleeve. The plastic should be chemically compatible with the solution being pumped, and care should be taken to protect the pump components against unnecessary wear and physical abuse.
2. Record all model and serial numbers for future reference. Always specify model number and serial number when ordering parts.
3. Pump flow curves are based upon pumping water. Increased motor horsepower may be necessary for pumping other liquids, or reduced motor horse power may be permissible when pumping at higher discharge head/low flow rates. Refer to Pump Curve.
4. Impellers are designed to offer maximum pump output and the motors are sized for non-overloading at maximum flow conditions.
5. Plastic piping has a high thermal expansion and this should be considered when attaching the discharge piping. Refer to Bulletin A-213 for pipe, pipe fittings, etc.

PLUMBING

When a suction line or suction extension is required, the pipe must be equal to or one size larger than the suction entrance. Make sure all couplings or connections are airtight. Bottom of the suction extension should always be at least 3 pipe diameters above the bottom of the tank. The use of a check valve on the discharge of the pump is recommended for either flooded suction or non-flooded suction. On a non-flooded suction, a foot valve on the end of the submerged suction line must be installed. Installing a priming 'T'-connection with a small valve between pump body and check valve will help to prime pump. (See Diagram 1)

RECOMMENDED PLUMBING UNDER NON-FLOODED CONDITIONS

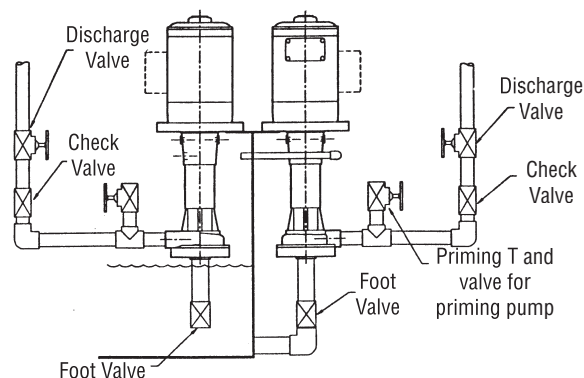

DIAGRAM 1

NOTE: Priming 'T' should be located just outside discharge or no higher than halfway between discharge and upper weep hole in pump housing, (Diagram 1). It is advisable to use a discharge valve after the check valve.

All plumbing and accessories must be supported other than by the pump to prevent possible distortion of the pump body. The correct liquid level is very important. If the liquid level is too high, it could cause motor damage. Recommended liquid level is halfway between the weep hole and the top of the volute. See Bulletin P-310 for exact dimensions.

NOTE: For out-of-tank installation, weep hole should be plumbed back to tank to prevent spills if tanks are inadvertently overfilled. (See Diagram 2)

RECOMMENDED LIQUID LEVEL

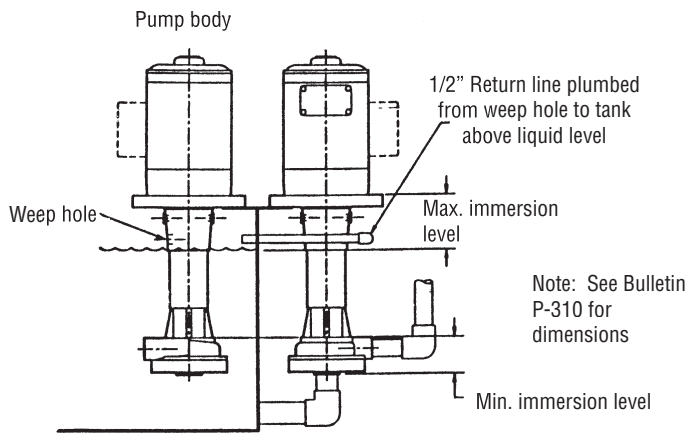

DIAGRAM 2

PRE START-UP

1. Verify that operating temperature is not in excess of pump design temperature. See Bulletin P-310.
2. Connect electrical supply to motor starter. Match voltage to nameplate voltage on motor. Incorrect voltage can cause fire or seriously damage motor, voiding warranty. If starter is furnished, verify that the starter is wired for the correct operating voltage with the correct overload heaters. It is recommended that a motor starter be installed for overload protection if one was not provided with the pump assembly.
3. Secure pump to corner of tank or sump and complete discharge piping. If pump is above a hot (160°F) liquid, it is recommended to support mounting plate on all four sides.
4. Pump rotation is counterclockwise when looking at the pump suction, or clockwise when looking down on the motor fan. (Check rotation arrow.) For 3-phase motors, it is necessary to verify correct direction of rotation by momentarily "jogging" the motor. An instantaneous "ON-OFF" of the starter is ample to check rotation. To change direction of rotation, interchange any two of lines L1, L2, or L3.

⚠ CAUTION: Extended running in reverse will cause pump damage, reduced performance and possible failure, voiding warranty.

To avoid possible problems, we recommend checking rotation without liquid to the pump. This eliminates torque to the impeller. This pump can run dry for extended time without damage.

1. ON NON-FLOODED conditions, manually prime pump through priming 'T' on discharge line.

⚠ CAUTION: DO NOT USE PUMP WEEP HOLE TO FILL PUMP as this could fill the impeller with liquid and result in damage at start up. Close all valves in discharge line, leaving suction fully open. A closed suction valve could result in damage to the impeller

and shaft. Start pump and open discharge valve slightly to allow any trapped air to escape. Then open discharge valve to desired flow rate.

2. Under FLOODED conditions (see Diagram 3), open valves on both suction and discharge to allow any trapped air to escape. Then close all valves on discharge side while leaving open all valves on suction side. Start the pump and slightly open discharge valve to allow any additional trapped air to escape. Then open discharge valve to desired flow rate.

RECOMMENDED PLUMBING UNDER FLOODED CONDITIONS

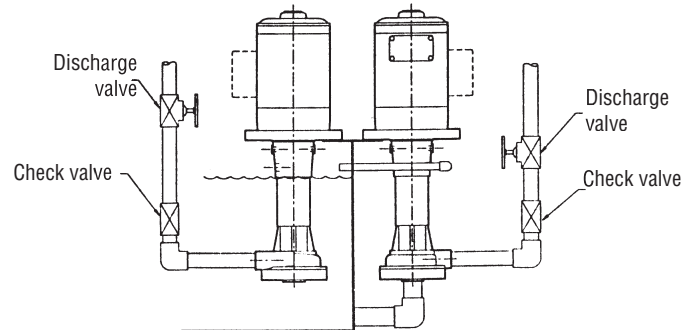

DIAGRAM 3

PUMP SERVICE

⚠ CAUTION: DISCONNECT POWER TO PUMP BEFORE SERVICING to avoid dangerous or fatal electrical shock hazards.

⚠ CAUTION: Before disassembly make sure pump is completely flushed and drained.

TOOLS NEEDED

- 1" threaded pipe nipple approximately 6" long
- 7/16" wrench
- 2 Screwdrivers (flat blade)
- Allen wrench 1/8"
- Dial indicator
- Rubber mallet

DISASSEMBLY

1. Lay pump horizontally on bench.
2. Unscrew suction retainer (J) counterclockwise. Remove suction cover (H) by inserting a 1" threaded pipe through center thread. Use a slight rocking motion while pulling outward.
3. To remove impeller (G), hold motor pump shaft (C) stationary by inserting Allen wrench through upper purge hole in body (F) into setscrew in shaft. **DO NOT LOOSEN SETSCREW.** Unscrew impeller (G) in counterclockwise (CCW) direction until loose and remove.

- To remove body (F) and mounting plate (M), loosen and remove four body bolts (D) from motor. Pull body straight off gently. **DO NOT ROCK**, as fume barrier (B) could become damaged. Removing the fume barrier (B) is only necessary when replacing it. If replacing, insert screwdriver and pry fume barrier out of fume barrier cavity.

NOTE: If shaft is removed or replaced, shaft alignment and spacing will be necessary.

- To remove pump shaft, loosen all four setscrews, protecting motor face with 2 blocks of wood or similar material. Pry shaft off motor with 2 screwdrivers. (See Diagram 6)

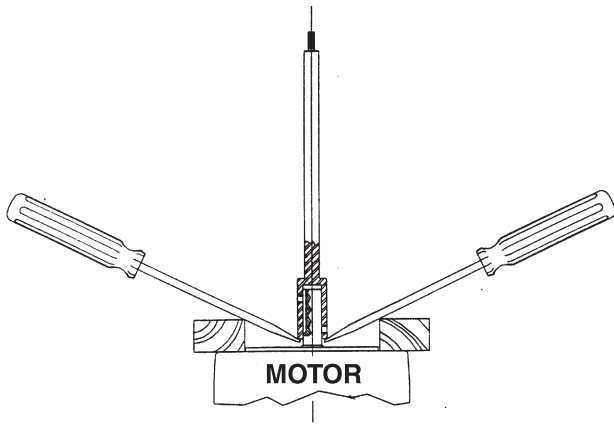

DIAGRAM 6

For motor maintenance, contact local authorized motor service center.

NOTICE: DISASSEMBLY OF MOTOR WILL VOID MOTOR MANUFACTURER'S WARRANTY

RE-ASSEMBLY

NOTE: Spacing is only necessary when replacing pump shaft. If not required, proceed to step #7

- Buffing motor shaft with emery cloth before reassembly is advisable to remove any burrs on shaft. Also check keyway for burrs.
- Place pump shaft on motor. Shaft should slide on all the way very easily. Align the single lower setscrew in keyway of motor (see Diagram 7). **DO NOT TIGHTEN AT THIS POINT.**
- Place 4 shims equal to .090" -.100" on motor face. (See Diagram 5) Two pennies or one penny and one dime stacked are close enough.
- Slide mounting plate (M) and pump body (F) carefully over pump shaft, seating it squarely over the motor face. Bolt mounting plate (M) and pump body (F) to motor face, snugging all four bolts (D).
- Insert Allen wrench through purge hole into setscrew in keyway. NOTE: **DO NOT TIGHTEN AT THIS TIME.** Screw impeller (G) onto shaft in clockwise direction until it bottoms out on pump body.

Tighten single setscrew at this point. With Allen wrench still in setscrew, unscrew impeller (G) and remove from body. Remove Allen wrench. Remove 4 bolts (D) in motor and remove pump body (F), mounting plate (M) and shims from motor face (see Diagram 5). Snug all setscrews.

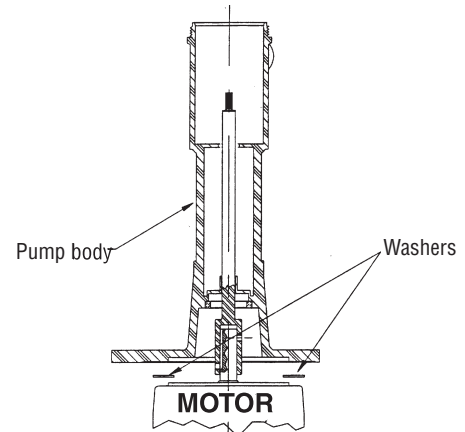

DIAGRAM 5

- If fume barrier (B) needs replacing, press into place with finger until it bottoms out. Lip indent of fume barrier should be towards impeller (F).

SHAFT ALIGNMENT PROCEDURE

The shaft now needs to be aligned so the total indicated runout (TIR) is less than .004"

- Place motor (A) vertically on bench.
- Attach a dial indicator with a magnetic base to the motor (see Diagram 7). The dial indicator should be set to run on the diameter as close to the end of the shaft as possible. (see Diagram 7)

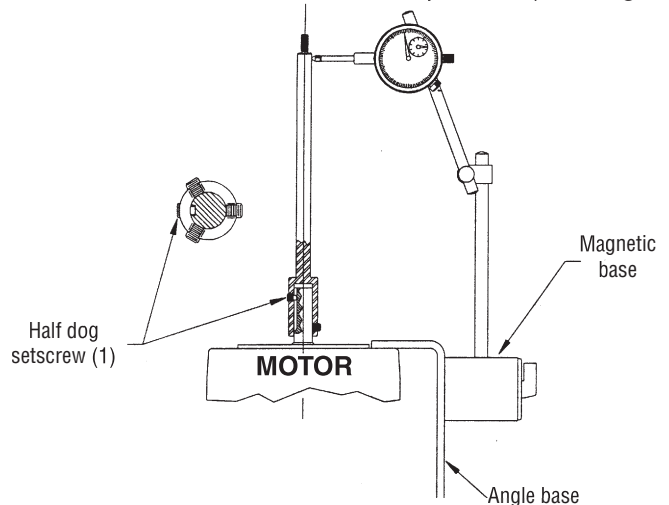

DIAGRAM 7

NOTE: If the magnetic base will not attach to the motor, a steel angle base can be attached to the motor. The magnetic base is then attached to the angle base.

Snug the 3 top set screws. Rotate the shaft to check for total indicator runout (TIR). If TIR is less than .004", continue to reassemble. If the TIR is more than .004", the shaft needs to be aligned by further adjusting the three cup point setscrews. (NOTE: When dialing in the shaft, always continue to tighten the set screws, never loosen any). For ease of alignment, find the side of the shaft which is the high point. Tighten the cup point set screw that is on the same side as the high point. If the high point is between 2 of the cup point set screws, you'll need to adjust both of them. If .004" TIR or less cannot be achieved, check pump shaft and/or motor shaft.

9. Place motor (A) with pump shaft (C) vertically on bench. Place mounting plate (M) and body (F) over shaft carefully, while passing over fume barrier (B) so lip is not torn or flipped. Insure mounting plate (M) and pump body (F) are completely on motor register by tapping lightly with rubber mallet or by hand. Note where discharge is positioned, then insert 4 mounting bolts (D) and washers (K) and tighten.
10. Hold pump shaft stationary by inserting an Allen wrench through upper purge hole into a setscrew. Screw impeller (G) on pump shaft by turning clockwise until snug. Rotate impeller (G) by hand to make sure there is no rubbing. If impeller rubs, replacing of pump shaft is necessary.
11. Before replacing suction cover (H), check "O"-ring (E). Check "O"-ring for cuts, nicks etc. and replace if damaged. Place suction cover (H) in pump, push in with the flat of your hand or tap with rubber mallet until seated squarely in body (F).
12. Replace suction retainer (J) by screwing on in aclockwise direction. Hand tighten.
13. With suction cover (H) and retainer (J) in place, once again rotate impeller to make sure there is no rubbing.

TROUBLESHOOTING

1. Motor Stops -

Check for correct voltage, wiring and motor direction. See that the starter has correct overload heaters. Take an amp meter reading at operating conditions and compare to value on motor nameplate. Measured value should be equal to or less than rated value. Check for friction-free rotation by turning motor fan with power disconnected.

2. Pump does not deliver correct flow -

Check suction strainer or pump inlet for debris. Compare required flow conditions to original specifications and pump curve. Check motor rotation.

3. Pumps up column at start-up -

Check liquid level and compare with recommended immersion levels shown on Bulletin OP-311.

4. Backflows up column at shut-down -

Check for large volume of liquid in pump discharge lines. If liquid is surging up the column, install a check valve in the discharge. Many different types of check valves exist. Each type has benefits and drawbacks which can adversely affect the pump. Test valves on water for proper operation.

5. Review parts list and maintain an inventory of recommended spare parts for emergency replacement. This will assure that the pump is returned to operation with minimum delay.

6. With pump running, listen for any unusual noise, vibration or other abnormal condition which could influence pump performance.

7. At maximum flow conditions, measure amperage on all lines. If in excess of motor nameplate ratings, stop pump and consult Sales Department.



SERFILCO[®], LTD.

2900 MacArthur Blvd. 847-509-2900
Northbrook, IL 60062-2005 U.S.A. 800-323-5431
e-mail: sales@serfilco.com FAX: 847-559-1995
www.serfilco.com