

REFILLABLE CARBON CANISTER

INSTRUCTIONS FOR CONVERTING FROM 'THREAD-IN' TO 'DROP-IN' DESIGN

MODELS: C528PE & C548PE

Refer to Bulletin R-102

IMPORTANT

This modification to the carbon chamber allows the C528PE and C548PE Maxi-Carb carbon cartridges to be used in lieu of the refillable canister or interchangeable with it.

1. Knock off bottom ring using wood chisel or sturdy blade.
2. Saw off threaded nipple close to bottom of canister and bevel ID of stub with knife blade.
3. Thread canister guide 88-1139 with "O"-ring into base of carbon chamber.
4. Drop canister over guide.
5. Compression spring 77-0301-1 is to be twisted into 'T' cap at top of canister. This prevents canister from floating off guide and will seal chamber cover.

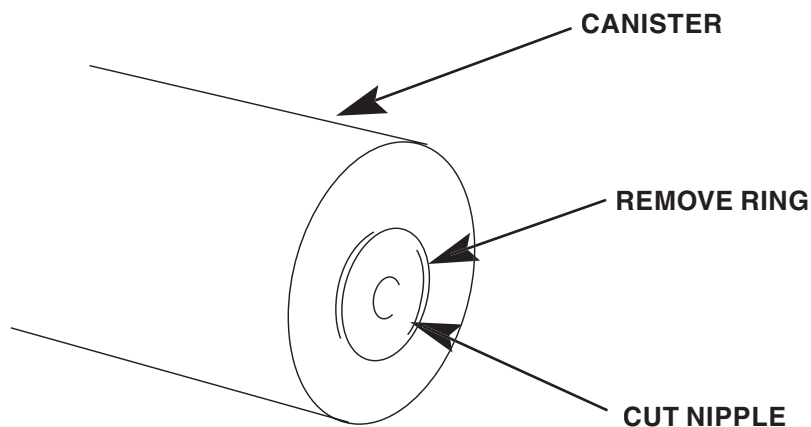

SERFILCO[®], LTD.

2900 MacArthur Blvd. 847-509-2900
Northbrook, IL 60062-2005 U.S.A. 800-323-5431
e-mail: sales@serfilco.com FAX: 847-559-1995
www.serfilco.com