



SKIM-DISC®

MODEL	PRICE CODE NO.
SD12-SS	99-0468
SD18-SS	99-0469
SD24-SS	99-2042

Refer to Bulletin A-108 and
Parts List PFS-807.

The **SKIM DISC** is shipped in four pre-assembled parts:

- Round skimming disk with two wiper blades.
- Bottom support and motor.
- Main trough assembly.
- Mounting bracket.

If you are using the 18" (45.7 cm) or 24" (61 cm) diameter disks, an extension plate is also attached to the bottom support.

Check all parts for shipping damage, tightness of screws, and freedom from nicks and burrs on the disk. Burrs can be removed with emery paper.

ASSEMBLY

1. Attach the disk to the face of the hub by using two 10-32 x 3/8" screws.
2. Fasten the main trough to the bottom support by using two 10-32 x 3/8" screws and two 1/4" flat washers. Center the disk evenly in the slot between the two wiper troughs.
3. Attach the wiper blades to the troughs under the flat washers and against the screws. The corner of the wiper blade should align with the edge of the disk. Tighten the screws.
4. Fasten the mounting bracket to the bottom support by using two 1/4-20 x 3/4" hex head screws, 1/4" lock washers, and 1/4" hex nuts, 2 each. The mounting bracket can be turned different ways and bent to facilitate installation.
5. Certain models of the SKIM-DISC are provided without wiring. In those cases wire from the motor to suit, using an appropriate approved electrical hookup. All units must be wired through a Ground Fault Circuit Interrupter. Mount the SKIM-DISC securely to the machine, free from splashing liquids. Follow all NEC, OSHA, and local electrical and safety code requirements.

INSTALLATION

Mount the SKIM-DISC securely to the tank where the surface of the fluid is still and calm. Mount the disk just below the surface of the fluid to be skimmed: usually one inch (25mm) or less is sufficient. If the surface of the fluid is rapidly moving or churning, operate the SKIM-DISC when the machine is shut down, such as during breaks, between shifts, or overnight.



**CAUTION: DO NOT USE SKIM-DISC ON
FLAMMABLE LIQUIDS.**

HIGH HEAT APPLICATION WARNING:

For high heat applications over 140°F (60°C) to 180°F (82°C), use 1/8" (3.2mm) thick stainless steel disk units only with sealed motors. **THE SKIM-DISC IS NOT RECOMMENDED FOR FLUIDS OPERATING AT TEMPERATURES OVER 180°F (82°C).**

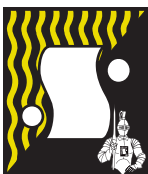
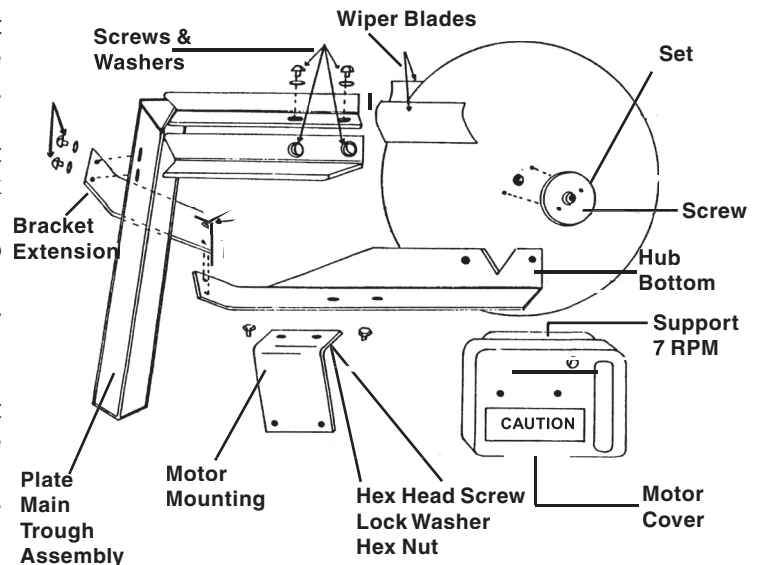

SERFILCO®, LTD.

2900 MacArthur Blvd. 847-509-2900
Northbrook, IL 60062-2005 U.S.A. 800-323-5431
e-mail: sales@serfilco.com FAX: 847-559-1995
www.serfilco.com