



SMART DRUM PUMP BATCH CONTROL SYSTEM



SERFILCO[®], LTD.

2900 MacArthur Blvd.

Northbrook, IL 60062-2005 U.S.A.

e-mail: sales@serfilco.com

847-509-2900

800-323-5431

FAX: 847-559-1995

www.serfilco.com

BATCH CONTROL SYSTEM

A. INTRODUCTION:

Thank you for purchasing a SERFILCO, Ltd. BATCH CONTROL SYSTEM (BCS). The BCS is a unique system specifically engineered to safely and efficiently control the transfer and metering of corrosive liquids. Read and understand the entire operating instructions for the pump, motor and system before operating the BCS. A complete system includes: Batch Control Motor, Control Module, Flow Chamber & Fittings and Pump End. Make sure you have all components before operation and setup.

NOT SUITABLE FOR FLAMMABLE OR COMBUSTIBLE LIQUIDS.

B. TECHNICAL DATA:

CONTROL MODULE —

Accuracy: +/- 0.5% (with Teach In function) – **recommended.**
+/- 1-2% (with Teach No function)

Repeatability: +/- 0.4%

Voltage: 120V/230V

Display: Digital LCD

Enclosure: IP 65, NEMA 4





FLOW CHAMBER / FITTINGS —

Measurement Principle: In-Line Turbine

Materials: Polypropylene units- Viton®, Ceramic, Carbon, Hastelloy C-276
PVDF units – PTFE, Ceramic, Carbon, Hastelloy® C-276

Discharge: 1" NPT or 1" hose barb

MOTORS —

52-8000 SB		115V/1/60 Hz. ODP motor with batch control connection
52-8001 SB		220V/1/50 Hz. ODP motor with batch control connection
52-3000 SB		115V/1/60 Hz. TEFC motor with batch control connection
52-3001 SB		220V/1/50 Hz. TEFC motor with batch control connection

Registered trademarks:

Viton - DuPont Dow Elastomers; Hastelloy - Haynes International

PUMP ENDS —

Pump Size	Polypropylene:	PVDF:
27" (700 mm) for carboys	PP-27	PVDF-27
39" (1000 mm) for drums	PP-39	PVDF-39
47" (1200 mm) for tanks	PP-47	PVDF-47
60" (1,500 mm) for IBC's	PP-60	PVDF-60
72" (1,800 mm) for large IBC's	PP-72	PVDF-72

SYSTEM —

Max. Flow Rate:	25 gpm (85 l/min)
Max. Pressure:	17 psi (1.2 BAR)
Max. Operating Temp:	PP units- 130°F (55°C) PVDF units- 175°F (80°C)

C. INSTALLATION (See page 9 for diagram.):

- Carefully unpack all items and visually inspect for damage during shipping.
- Attach Batch Control Motor to Pump End by placing motor onto pump coupling and tighten handwheel. Make sure the motor and pump couplings are connected properly.
- Unscrew wing nut ([PP] P-52-1106, [PVDF] P-52-4106) and hose barb([PP] P-52-1082, [PVDF] P-52-4082) from Pump End. Threads on the discharge housing will be visible.
- Fasten Flow Chamber to pump discharge. Make sure the wing nut is tightened securely.
- Place the ¼ turn Control Module (448338M) onto the True Union Flow Chamber (PP-423958S, PVDF- 423970S). Fasten Control Module with set screw for added safety.
- Connect communication cable into motor handle.
- Plug power cord to motor into appropriate outlet. The display on the Control Module will illuminate. A Serial number will flash and the Control Module will run through a systems check, followed by

BATCH M

D. PROGRAMMING:

The BCS unit contains a menu in which users can customize programmable settings. These settings include: units of measure, language display and calibration options.

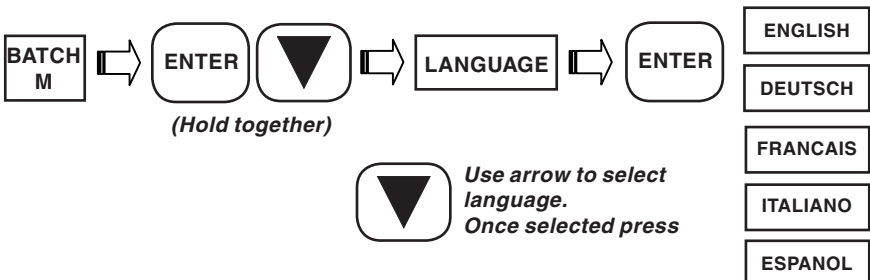

Use arrow to select unit

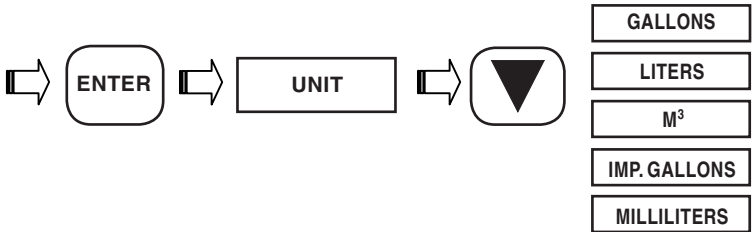

Use arrow to select flow unit of measure

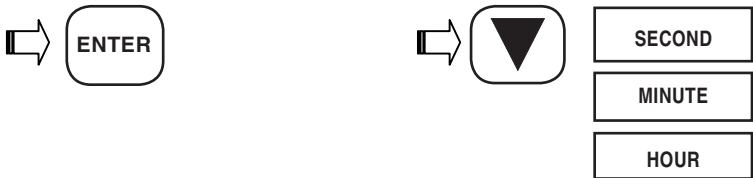

"TEACH IN" FUNCTION – RECOMMENDED METER CALIBRATION FOR BEST ACCURACY. FOLLOW STEPS (1A-3A)

Obtain a measured vessel with the same unit of measure entered under the UNIT section. Move motor switch to the ON position. NOTE: The pump WILL NOT engage at this time.



WARNING: PRESSING ENTER WILL ENGAGE PUMP SO MAKE SURE ALL CONNECTIONS ARE SECURE AND PROPER SAFETY PRECAUTIONS HAVE BEEN TAKEN.



Once the vessel is filled to the measured level disengage the BCS by:



The K-Factor will be saved in memory until re-calibrated.

"TEACH NO" FUNCTION – quick calibration when speed is most important



Step (2) *Choose the proper K-Factor from chart & enter*

K-factor value for PP flow chamber			K-factor value for PVDF flow chamber		
S.G.	Liters	Gallons	S.G.	Liters	Gallons
1.0	55.0	208.175	1.0	59.17	223.95845
1.1	55.3	209.3105	1.1	59.47	225.09395
1.22	55.6	210.446	1.22	59.77	226.22945
1.3	55.9	211.5815	1.3	60.07	227.36495
1.4	56.2	212.717	1.4	60.37	228.50045
1.5	56.5	213.852	1.5	60.67	229.63595
1.68	56.83	215.1015	1.68	61.00	230.885
1.77	57.17	216.3884	1.77	61.34	232.1719
1.89	57.5	217.6375	1.89	61.67	233.42095

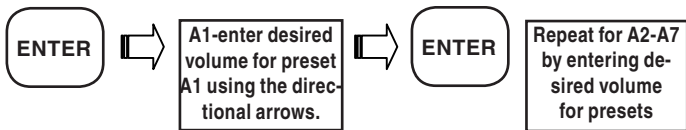
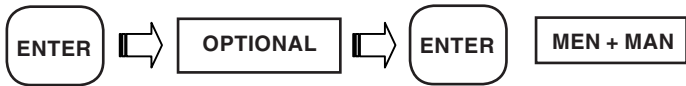
All (7) Presets do not have to be used. Scroll through the unused settings by pressing:



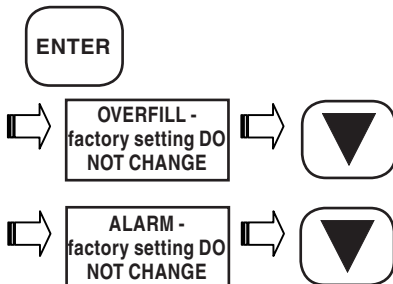

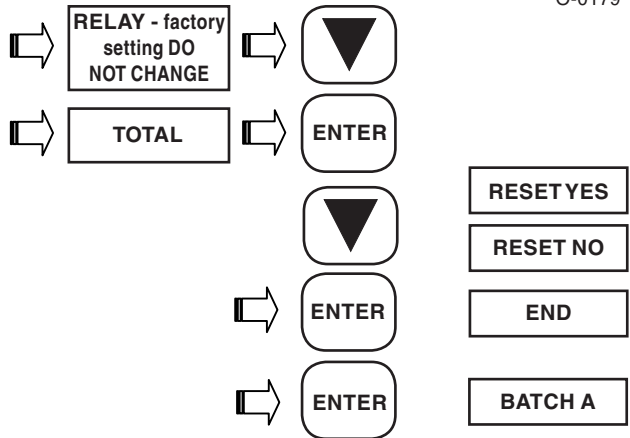
This indicates you are back at the Main Menu.

E. OPERATION / AUTO-BATCHING



Use arrows to select preset A1-A7.



Note: The displayed selected preset volume will flash between the A1 and the volume set



Use arrows to select Yes or No.

PUMP WILL ENGAGE AND DISPENSE THE PRESET VOLUME.

During operation press the  to view the flow rate.

After the preset volume is dispensed the BCS will disengage and complete the process. The Preset A1-A7 (the preset just used) will show on the display.

A1-A7

Option
To run a Batch again (proceed as above).

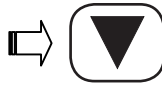

Use arrow to scroll through preset A1-A7 to choose another Preset (proceed as above) or return to Main Menu.



F. MANUAL BATCH:



Return to Main Menu

Use arrows to select BATCH M

Use arrows to enter

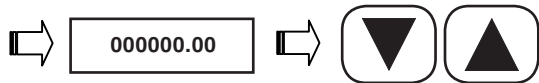

Use arrows to select Yes. (Selecting No will default back to the Main Menu BATCH M to start again).



PUMP WILL ENGAGE AND DISPENSE THE PRESET VOLUME.

After operation is completed the display will default to the set volume and is ready to run another BATCH.

Option to run another BATCH

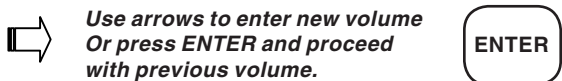

G. SAFETY FEATURES:

DURING OPERATION TO PAUSE THE SYSTEM.

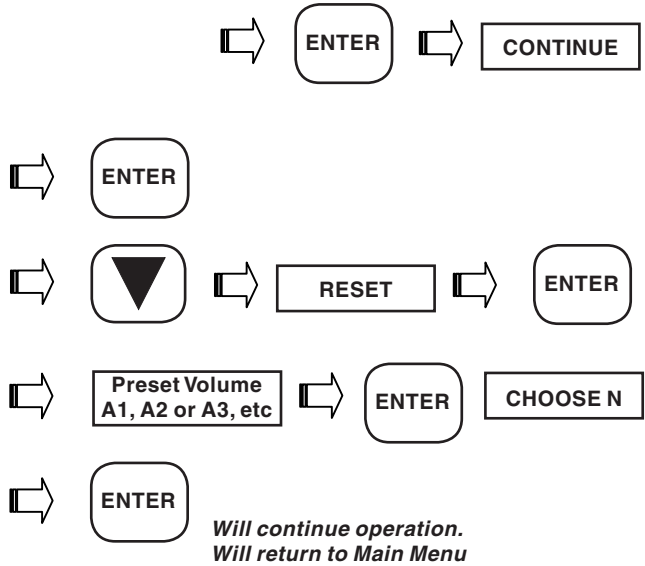

TOTAL

Displays Main Total Volume. Reset in the Calibration Mode, see above.

TOTAL

Displays Daily Total Volume for the last 24 hr. period. Reset by holding both arrows in for 2 seconds.

H. MAINTENANCE:

In correct installation conditions the flow sensors and totalizers are maintenance – free. If contamination or clogging should occur during operation, the transmitter, (paddle wheel, bearing) can be cleaned with water or another appropriate cleaning agent.

The message **ERROR** indicates that the calibration data has been lost. The device must be re-calibrated. If this message appears often, please return to factory.

BATCH CONTROL SYSTEMS REPLACEMENT COMPONENTS

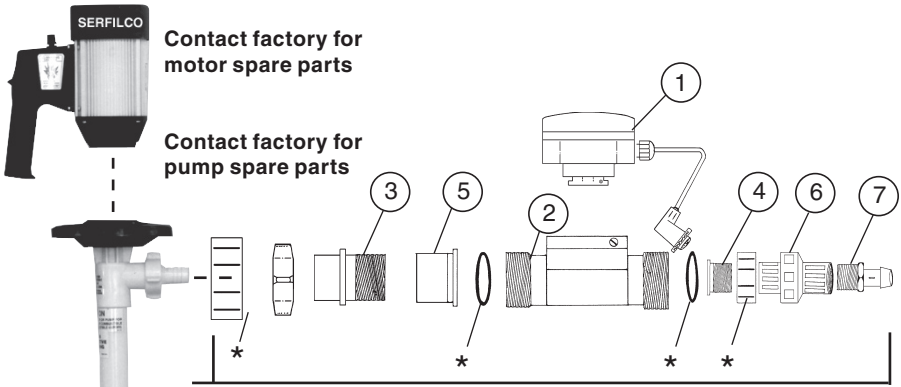

Flow Chamber Assembly

ITEM NO.	PART NUMBER	DESCRIPTION
1	448338M	Batch Control Module, 115/220V (cable connection included)
	USPPFC	1" PP True Union Flow Chamber Assy. (Includes the following items 2-7)
2	423958S	1" PP True Union Flow Chamber
3	US61652	1" PP MNPT pump outlet fitting
4	US61653	1" PP MNPT flow meter outlet fitting
5	US61654	1" PP FNPT flow meter inlet fitting
6	US61655	1" PP check valve
7	US61659	1" PP MNPT hose barb fitting
	USPVDFFC	1" PVDF True Union Flow Chamber Assy. (Includes the following items 2-7)
2	423970S	1" PVDF True Union Flow Chamber
3	US61661	1" PVDF MNPT pump outlet fitting
4	US61662	1" PVDF MNPT flow meter outlet fitting
5	US61663	1" PVDF FNPT flow meter inlet fitting
6	US61664	1" PVDF NPT check valve
7	US61665	1" PVDF MNPT hose barb fitting

* = Part of item #2 flow chamber

— NOTES —

O-0179

— NOTES —

O-0179

BATCH CONTROL SYSTEM TEST

Conditions:

Temperature: 70°F/20°C
Pressure: 15 psi
Fluid: Water
Test Fitting: 1" PVC

Results:

Flow Rate: 25 gpm (95 l/min)
Accuracy: +/- 0.5%

Tested on:

Tested by:

We hereby declare that the design and operation of this pump system meets the enclosed factory specifications.

Manufacturer:

Serial Number: