



SERFILCO® TITAN PROCESS SYSTEMS (Acid - AC, Alkaline - ALK)

OPERATION AND SERVICE GUIDE
O-3070E
JAN. 2003

MODELS			
P50AC P50ALK	P70AC P70ALK	P150AC P150ALK	P200AC P200ALK

! Titan Systems are not designed for use with flammable or explosive products.

Refer to Bulletin F-455.

HANDLING

A forklift should be used for handling Titan systems. If the entire system is on a base, use a forklift making sure the forks are placed under the base, not under the chamber. When a chamber is not attached to the base, use the ears/handles that are welded on top of the chamber for handling. **DO NOT USE THE COVER HOLD DOWN BRACKETS FOR THIS PURPOSE.** Place straps or chains of sufficient strength in each ear and use a forklift to lift the unit to prevent damage to the chamber. Use care to prevent the chamber from swaying.

PLUMBING

Locate the Titan process system as close to the process tank as possible. The system's pump is not self-priming. A flooded suction is required to maintain proper prime for the system to function properly. It is strongly suggested to avoid the use of elbows on the suction supply line for the pump. The total flow rate will be decreased by 2.5 gallons per hour for every 90-degree elbow on the suction side. Do not place an elbow within 10 pipe diameters of the suction supply line of the unit. If elbow use is unavoidable or to keep the suction intake piping run as short as possible, the pipe size for the suction intake will have to be increased to compensate for restriction and friction loss. Do not decrease the pipe size of the suction or the discharge. The discharge return line should come up and over the side of the tank and be positioned just above the solution level. Increasing the final 4 feet of the discharge pipe by 1 inch will minimize splashing during the blow-down cycle. PVC schedule-80 pipe is recommended for solutions to 140°F maximum and CPVC for solutions to 200°F maximum, for plumbing the Titan filter to and from the process tank, backflush tank, and to waste treatment. Please feel free to contact SERFILCO's Sales Department to review your plumbing layout or other areas of concern prior to installation.

The installation of a _____ gallon, fresh water tank located near the filter unit is necessary for the backflush cycle.

On AC models (which are designed for processing acid solutions), the system's pump is constructed of CPVC with a double mechanical seal that requires a constant, low volume flow of fresh water. For optimum seal performance and longevity, an incoming flow of 4 gallons per hour at 15 PSI above the pump's operating pressure must be provided to the seal chamber. On ALK models (which are designed for processing alkaline solutions), the system uses a single mechanical seal cast iron pump.

ELECTRICAL

The 3-phase filter units are factory wired to your specific primary voltage. Install a 3-phase line to the control panel and connect the power to the top of the main disconnect switch. The installation of an external fused disconnect switch near the unit is recommended. No further wiring is required. The pump and all valves are individually fused inside the control panel.

Rotation for the system's pump motor must be correct. A rotation arrow affixed to the motor indicates proper rotation. View the motor from the fan end and bump start the pump motor by pressing the center of the contactor located inside the control panel to verify correct rotation.

Should a cycle change be required, consult the factory. Any unauthorized change in the PLC program by other than SERFILCO service personnel will void the warranty.

AIR SUPPLY

A 1/2" air line, with a minimum of 50 PSI @ 30 CFM, needs to be installed and connected to the filter/regulator provided on the unit.

REGULATORS

The unit is equipped with a main filter regulator, a regulator for blow-downs #1 and #2, and a backflush regulator.

Adjustment - Pull adjustment knob upward to unlock. Turn clockwise to increase and counterclockwise to decrease outlet pressure setting. To reduce pressure, first reduce to a pressure less than desired, then increase to the desired outlet pressure. Push adjustment knob downward to re-lock.

Servicing

1. Keep accumulated water below baffle on the main filter/regulator by observing level through sight glass located on the filter housing. Open valve on bottom of housing to drain.
2. Replace filter element when dirty.

MEDIA

AC Models: coarse — pea gravel
fine — sand

ALK Models coarse — anthracite #2
fine — anthracite #1

The TITAN filter is shipped without media in the chamber. On some models, coarse media will be installed.

Remove the cover of the filter chamber and cover laterals with water. Slowly add _____ lbs. of coarse media followed by _____ lbs. fine media. Level off the media and replace and secure the filter chamber cover.

ALK Models (anthracite) for alkaline solutions -

Cover media with water and let stand a minimum of 24 hours. This will increase its density to allow proper backflushing of the system.

Replace and secure the filter chamber cover.

START-UP

Media will always contain fine particles and should be manually backflushed to waste treatment prior to initial start-up or when changing media.

1. Fill the backflush tank with fresh clean water.

2. If installed, open all manual valves.
3. Turn the air supply on and adjust main filter/regulator pressure to 50 PSI.
4. Adjust the blow-down #1 and #2 regulator to 10 PSI.
5. Adjust the backflush regulator to 20 PSI.
6. Turn the water supply line for the Dri-Stop pump protector on and adjust to a rate of 4 GPH or greater @ 15 PSI above discharge pressure.
7. Turn the main disconnect switch on.
8. Turn the power switch on.
9. Turn the mode switch to hand position.
10. The blowdown light will begin flashing. When this light becomes steady,
 - a. Press the manual step button switch to bypass the blow-down #1 cycle to the backflush cycle.
 - b. The pump will come on for 30 seconds and automatically shut off.
 - c. Backflush air will come on for 60 seconds.
 - d. Air will shut off. After 30 seconds pump will come on again. To prevent the pump from running dry, you must time this manually for 180 seconds or until your backflush tank nears empty.
 - e. Press the step button switch to blow-down #2. Manually time this for 9 minutes.
 - f. Turn the mode switch to off.
 - g. The pump suction feed line must be entirely filled.
 - h. Turn the mode switch to automatic. The filter light will flash and in a few seconds the pump will come on. If no flow appears on the flow meter after approximately 45 seconds, turn the mode switch to off for one minute. This will allow trapped air to escape the pump head. Repeat this procedure until full flow is established.

As the contaminants build up in the filter media and slow the flow rate down to the low setting point, the unit will go into an automatic backflush cycle. The red light marked relay-1 on the flow meter will appear steady for 3 minutes before this takes place.

FLOW METER

The low flow set point has been pre-calibrated for typical operation at the factory. If the settings need to be adjusted, refer to the flow monitor instructions included in your booklet on how to enter the calibrating menu to adjust the low flow setting.

VALVES

⚠ CAUTION: Before any maintenance is performed and to prevent ignition of hazardous atmospheres and reduce the risk

of electrical shock, never remove actuator covers while circuits are live.

If a fault alarm occurs from an out-of-position valve, consult factory for proper procedure to correct the problem. Valves are manufactured with factory lubricated grease in the gear case. In most cases this lubricant should never have to be replenished.

SHUTDOWN

Turn the mode switch to the off position. All of the electric valves will turn to their closed positions. After ten seconds turn the power switch to off. It is suggested that all manual valves be turned to their closed positions. This will assure no solution loss due to a siphoning action.

The Titan filter has a power failure circuit built in. If you experience a power failure, the filter unit will not restart automatically. To restart the system, turn the mode switch to the off position and then back to auto.

Little or no maintenance is required on this filter unit. However, the unit should be periodically checked for plumbing leaks, air leaks, etc. The control panel door must be locked at all times.

MANUAL BACKFLUSHING PROCEDURE

⚠ CAUTION: Do not use the start-up procedure to perform a manual backflush.

When performing a manual backflush, the pump will not shut off automatically. It is crucial to time step #3 (below) to prevent the pump from running dry. Review the valve positions/cycle times sheet for total minutes of operation procedures.

1. Turn the mode switch to the hand position.
2. The blowdown light will begin flashing. When this light shines continually, the unit will begin with blowdown #1 pushing the solution inside the chamber back to the process tank. This must be timed for 9 minutes and then press the manual step button switch.
3. The unit will now go into backflush. This must be timed for 5 minutes or until the backflush tank nears empty. Immediately press the manual step button.
4. The unit will begin with blowdown #2 pushing the water inside the chamber to waste treatment. After 9 minutes, turn the mode switch to the auto position to return to filtration.

MAINTENANCE

When and if cleaning of the tank is required it must be done in accordance with the regulation in force in the country and the product.

ACID PROCESS FILTER TROUBLESHOOTING	
PROBLEM	SOLUTION
1. Pump will not come on:	a. Check 3 phase fuses. b. Verify water is flowing through the Dri-Stop at a minimum of 4 GPH.
2. Fault light comes on:	One of the valves is out of position, which is the only cause for the fault alarm to come on.
3. Flow rate not returning to the original value after automatic backflush:	a. Media may be over-contaminated. Proceed with a manual backflush. b. If manually backflushing does not correct the problem, proceed with a backflush again. After blow-down #2 is complete, turn system off. Remove the filter chamber cover and fill chamber with 50% muriatic acid until the media is covered. Allow to stand a minimum of 12 hours with the cover loose. Proceed with a manual backflush.
4. Losing media:	Broken or cracked plumbing inside chamber. Remove media and inspect. Repair as necessary.

FLOW DIAGRAM

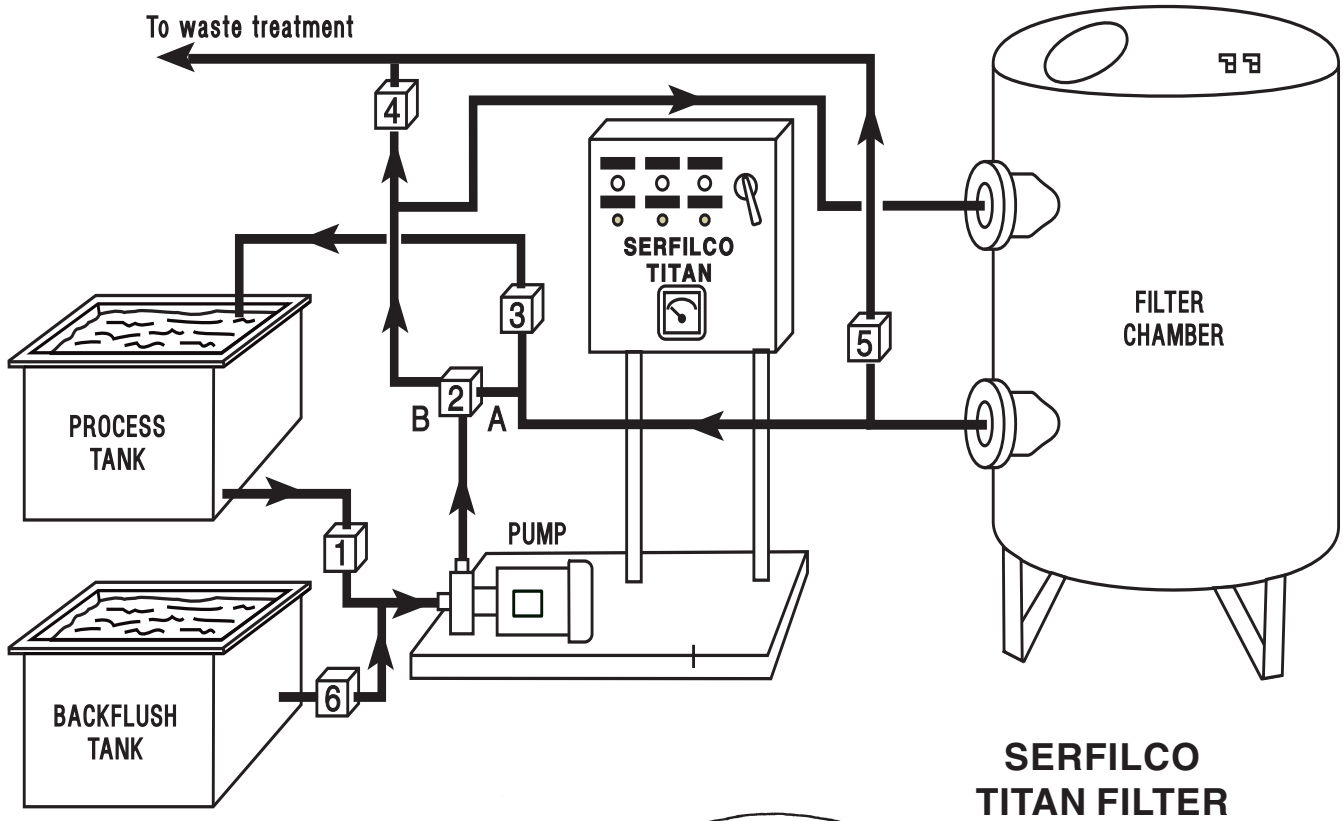

SERFILCO TITAN FILTER

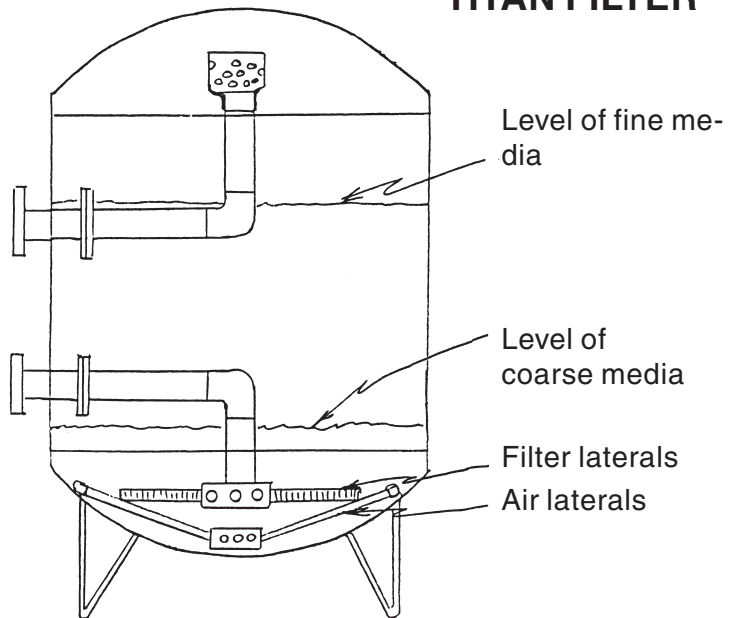

VALVE POSITIONS / CYCLE TIMES

FILTRATION

PUMP	VALVE 1	VALVE 2		VALVE 3	VALVE 4	VALVE 5	VALVE 6	VALVE 7	VALVE 8
On	Open	A Closed	B Open	Open	Closed	Closed	Closed	Closed	Closed

BLOWDOWN 1

PUMP	VALVE 1	VALVE 2		VALVE 3	VALVE 4	VALVE 5	VALVE 6	VALVE 7	VALVE 8- air
Off	Closed	A Open	B Closed	Open	Closed	Closed	Closed	Closed	On - 3 minutes Off - 2 minutes On - 1 minute Off - 1 minute On - 30 seconds Off - 1 minute On - 30 seconds <hr/> 9 minutes

BACKFLUSH

PUMP	VALVE 1	VALVE 2		VALVE 3	VALVE 4	VALVE 5	VALVE 6	VALVE 7 - air	VALVE 8
On	Closed	A Open	B Closed	Closed	Open	Closed	Open/ Closed	Pump On - 30 seconds VALVE 7 - air On - 1 minute Off - 30 seconds Pump - On - 3 minutes 5 minutes <hr/>	Closed

BLOWDOWN 2

PUMP	VALVE 1	VALVE 2		VALVE 3	VALVE 4	VALVE 5	VALVE 6	VALVE 7	VALVE 8- air
Off	Closed	A Open	B Closed	Closed	Closed	Open	Closed	Closed	On - 3 minutes Off - 2 minutes On - 1 minute Off - 1 minute On - 30 seconds Off - 1 minute On - 30 seconds <hr/> 9 minutes

WARRANTY

SERFILCO warrants products* of its own manufacture will be free from defects in raw materials and manufacture under normal use and service for a period of not more than one year after date of shipment. **SERFILCO**'s obligation under this warranty is limited to repair or replacement of its products which shall be returned to **SERFILCO**'s headquarters, Northbrook, Illinois, U.S.A., with all transportation and associated charges prepaid, and which examination shall disclose to **SERFILCO**'s satisfaction to have been thus defective at time of shipment, provided that **SERFILCO** had received immediate written notice upon discovery of such alleged defect and the alleged defective products shall have returned to **SERFILCO** not later than 30 days after **SERFILCO** has issued a Return Authorization Number. This warranty shall not apply to any of the products which shall have been used other than for their intended use, nor to any of the products, the composition of which shall have been changed in any way, nor to any of the products which have been subject to adverse storage conditions, misuse, negligence or accident.

SERFILCO shall not be held liable for damage or delays caused by defective raw materials and manufacture, nor shall **SERFILCO** be liable for consequential damages in cases of failure to meet the conditions of warranty. The full liability of **SERFILCO** under this clause is the repair or replacement of defective parts, at its discretion.

The customer is responsible for the proper installation and operation of the equipment. A factory representative is available at start-up at cost of travel expenses plus charge per diem. Consult Sales Dept.

* Products such as filter cartridges do not normally last one year and may require frequent replacement. In addition, certain components such as mechanical seals, springs, "O"-rings, hose, ceramic liners, impeller magnet assemblies, diaphragms, etc. may be subject to wear and, therefore, wear should not be construed as evidence of the existence of a defect, and as such will not be honored in a warranty claim, nor should it be inferred that items such as these will last a year without occasional, or even frequent, replacement depending upon the severity of the application. Items not of **SERFILCO**'s manufacture, such as motors, carry similar warranties by the manufacturer, and can often be serviced through local authorized repair center or handled through our office.

This express warranty is given in lieu of all other warranties. All other warranties and, specifically, the implied warranties of merchantability and fitness for particular purposes, are excluded. No person, agent or representative of **SERFILCO** is authorized to give any other warranties on **SERFILCO**'s behalf or to assume for it any other liability in connection with any of the products.

! WARNING — Any modification, alteration or other changes to **SERFILCO**'s products will void any warranty and could cause damage or injury to the user of the products.

RETURN AUTHORIZATION POLICY

Inasmuch as **SERFILCO, Ltd.** produces products which are in industrial / commercial applications wherein these products come in intimate contact with chemicals, solvents, or other substances which may be classified as hazardous substances, and there exists federal, state and local legislation defining responsibilities and liabilities with regard to the generation, transportation, storage, and disposal of such substances, and that these same products may be returned to **SERFILCO** for service or other reasons after coming in contact with such substances, the following applies to return of used equipment.

USER RESPONSIBILITY

It is assumed that the user of **SERFILCO, Ltd.** products is in compliance with all aspects of legislation dealing with hazardous substances. To that end, the procedures for the legal transportation and disposal of such substances are the sole responsibility and liability of the user. Prior to any return of used merchandise the user shall:

1. Contact **SERFILCO, Ltd.** to obtain a Return Authorization Number and specific shipping instructions.
2. Thoroughly cleanse the merchandise to be returned so that no detectable residue of any substances remains on any surface.
3. Prepare a legal shipping container suitable for the return of this merchandise to **SERFILCO, Ltd.** The shipping container must have the Return Authorization Number clearly and legibly imprinted above the shipping label.
4. The user is responsible for shipping the merchandise to **SERFILCO, Ltd.** and for the freight charges in both directions.
5. PLEASE NOTE: In the presence of the delivering carrier, **SERFILCO** personnel will open and inspect all returned merchandise, and will refuse and return to shipper all merchandise not meeting these conditions.
6. Assume responsibility for the final disposition of any used merchandise i.e., reuse of a repaired or otherwise reusable product, or the legal disposal of a defective or otherwise unusable product.
7. Used filter media, carbon or ion-exchange resins may not be returned to **SERFILCO, Ltd.** and will be refused.
8. Samples for test will not be accepted. **SERFILCO** offers rental and test equipment for field testing, subject to the above conditions.

In the event that used merchandise is returned to **SERFILCO, Ltd.** without strict compliance to this policy, **SERFILCO** reserves the right to refuse receipt of such products. **SERFILCO** will direct that the carrier involved return same to sender in accordance with the above policy and procedure.

SERFILCO TITAN PROCESS

VALVE POSITIONS

PROCESS	PUMP	VALVE 1	VALVE 2		VALVE 3	VALVE 4	VALVE 5	VALVE 6
			A	B				
Filter	On	Open	Closed	Open	Open	Closed	Closed	Closed
Blowdown 1	Off	Closed	Open	Closed	Open	Closed	Closed	Closed
Backflush	On	Closed	Open	Closed	Closed	Open	Closed	Open
Blowdown 2	Off	Closed	Open	Closed	Closed	Closed	Open	Closed
Shut down	Off	Closed	Open	Closed	Closed	Closed	Closed	Closed

PLUMBING SCHEMATIC

