

SERIES 'HE' PLASTIC HORIZONTAL PUMP

MODEL: H2 x1½

OPERATION AND
SERVICE GUIDE
O-820Q
MARCH 2002

Refer to Bulletin P-201 and Parts Lists: P-7200, P-7250.

! SAFETY PRECAUTIONS BEFORE STARTING PUMP

1. Read operating instructions and instructions supplied with chemicals to be used.
2. Refer to a chemical resistance data chart for compatibility of materials in pump with solution to be used.
3. Note temperature and pressure limitations.
4. Personnel operating pump should always wear suitable protective clothing: face mask or goggles, apron and gloves.
5. All piping must be supported and aligned independently of the pump.
6. Always close valves slowly to avoid hydraulic shock.
7. Ensure that all fittings and connections are properly tightened.
8. **! Ground motor before connecting to electrical power supply. Failure to ground motor can cause severe or fatal electrical shock hazard. DO NOT ground to gas supply line.**

! BEFORE CHANGING APPLICATION OR PERFORMING MAINTENANCE

1. Wear protective clothing as described in Item 4 above.
2. Shut off power to motor at disconnect switch.
3. Flush pump thoroughly with a neutralizing solution to prevent possible harm to personnel.
4. Verify compatibility of materials as stated in Item 2 of Safety Precautions above.

! IMPORTANT

1. Pump is constructed entirely of plastic; all fasteners are stainless steel. Shafts are medium carbon steel protected by a plastic sleeve. The plastic may be chemically compatible with the solution being pumped, but care should be taken to protect the pump components against unnecessary wear and abuse. Confirm seal material compatibility.
2. Record all model and serial numbers for future reference. Always specify model number and serial number when ordering parts.
3. Review Parts List and maintain an emergency inventory of replacement items to assure that pump is returned to service with the least delay.
4. Pump flow curves are based on pumping water. Increased motor horsepower may be necessary for pumping other liquids or reduced motor horsepower may be permissible when pumping at higher discharge head. Refer to pump curves on Bulletin P-201.
5. All units are factory tested to meet published or specified flow rates and to confirm that the seal assembly

functioned properly at time of shipment.

6. **Single mechanical seal pumps can not run dry. In most cases, operating the pump without liquid for less than 1 minute will severely damage the pump and void the warranty.**
 7. **Double mechanical seal pumps require a constant flow of fresh water through the seal chamber when the pump is operating.** For optimum seal performance and longevity, an incoming flow of 8 GPH @ 15 PSI above pump operating pressure must be provided to the seal chamber. (It is recommended that a valve be fitted to the outlet of the double seal chamber to enable adjustment of flow rate.)
- ! CAUTION:** Do not use double water flushed seal with concentrated sulfuric acid or solutions having high 'heats of solution'. These types of solutions will have an exothermic (extremely high heat) reaction when mixed with water.
8. NOTE: Pump inlet piping should be one to two sizes larger than pump suction size for long suction lines, operation near vaporization temperature and/or low atmospheric pressure (high elevation). Refer to Bulletin A-213 for pipe, fittings, etc. Be aware of the high rate of thermal expansion of plastic pipe when piping to a pump. Refer to PRE START-UP instruction No. 10.
 9. Maximum pressure produced by pump with 1.0 S.G. solutions -
 - A. 60 PSI on 60 Hz - 3450 RPM motors
 - B. 300 KPa on 50 Hz - 2850 RPM motors
- Do not subject pump to pressures over 22 PSI or 151 KPa when motor is not running. Mechanical seal faces can separate and leak.
10. When recirculating, use syphon breaker to prevent solution loss due to malfunction.
 11. Dri-Stop pump protector is recommended for prevention of pump damage during abnormal operation. See Bulletin A-105 and Operation and Service Guides O-1680 & O-1685.

PRE START-UP

Read items 1-10 below and cavitation supplement page, before starting pump.

1. Verify that operating temperature is not in excess of pump design temperature.
2. For Double Mechanical Seal Pumps,
 - a. Connect fresh water lines to the inlet and outlet fittings located on the back side of the pump.
 - b. Begin flow of fresh water
 - c. Visually confirm water flow at outlet of seal chamber
3. Install Dri-Stop Protector per Operation and Service Guide O-1680 or O-1685. (optional/recommended)
4. Connect electrical supply to motor starter. Match volt-

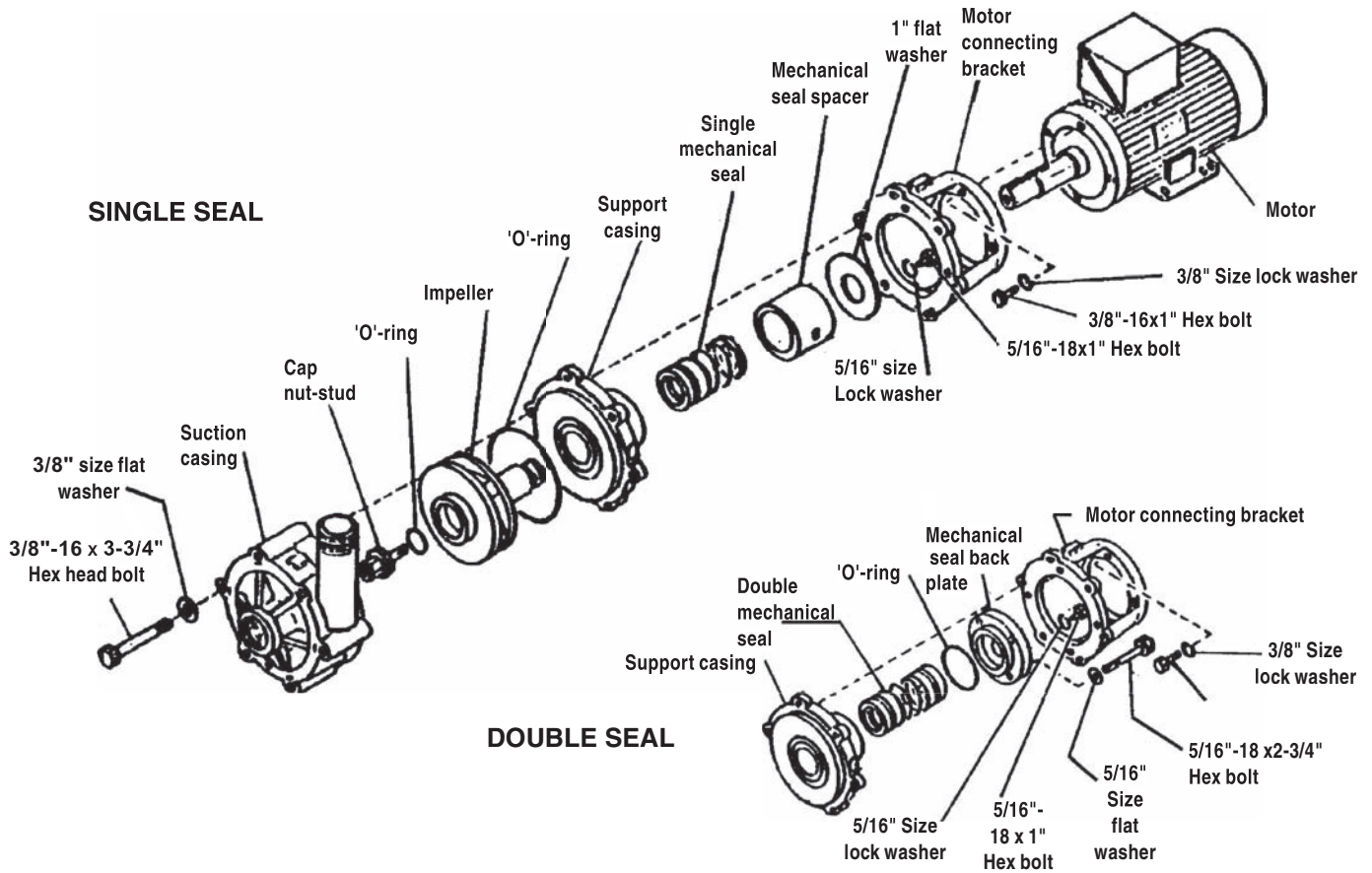

- age to nameplate voltage on motor. Incorrect voltage can cause fire or seriously damage motor, voiding warranty. Verify that starter is wired for the correct operating voltage and correct overload heaters. It is recommended that a motor starter be installed for overload protection, if one was not provided with the pump assembly. Wire in accordance with local codes and motor operating instructions.
- Pump rotation is counterclockwise when looking at the pump suction, or clockwise when looking down on the motor fan. (Check rotation arrow.) For 3-phase motors, it is necessary to verify correct direction of rotation by momentarily "jogging" the motor. An instantaneous "ON-OFF" of the starter is ample to check rotation. To change direction of rotation, interchange any two of lines L₁, L₂, or L₃.
NOTE: Incorrect rotation will cause pump damage, reduced performance or failure, voiding warranty.
 - WARNING!** Do not operate pump without liquid as immediate damage to the mechanical seal and support casings will result. Check pump rotation only with liquid in pump.
 - Some models require a shim under the motor base so that the pump suction casing is above the motor mounting surface. Do not fasten the motor in place without a shim if one is required.
 - Install a strainer on the pump suction to prevent foreign material from entering the pump and possibly causing impeller damage. The pump is constructed of plastic for chemical resistance and does not have the shock resistance of cast steel.
 - Do not over-tighten suction and discharge connections

to the pump body. To prevent leakage at these points, it is suggested that TFE tape be used on the threads rather than a pipe compound.

- IMPORTANT:** Pump suction is 2" NPT, discharge is 1½" NPT. Suction pipe or hose should **never** be less than 2" I.D. For long suction lines in excess of 15 ft. of 2" hose or 10 ft. of 2" **straight** pipe, the next larger hose or pipe should be used. This is especially important for 3, 5, & 7.5 HP models when pumping at elevated temperature, high elevation, or when suction line includes several elbows. The preceding conditions contribute to pump cavitation which results in under performance and premature failure of pump components. Suction pipe velocities should be as low as possible. An increase in suction pipe size will accomplish this. Suction pipe or hose should be as short and straight as possible with a minimum of pipe fittings. Refrain from using elbows or tees in the suction. Do not install any elbows within 10 pipe diameters of the suction.
- Do not install valve on suction line for throttling/controlling pump flow. A valve in the suction line should only be used as a stop valve when the pump is removed for servicing. A ball valve is recommended for this application. A flow control valve should only be installed on the pump discharge.
- IMPORTANT:** Considerable damage will result from the rapid temperature rise which will occur if the pump is run against a closed discharge valve.

START-UP

1. The series 'HE' horizontal pump is not self priming. Pump is designed to have a flooded suction at all times. It is suggested that during initial start up, the discharge valve be partially closed and then opened as the motor develops full rpm's. If pump does not build up pressure as motor speed increases, shut down and reprime pump. Make sure that liquid flow into pump is not restricted.
2. Operate pump for 2 - 4 minutes then de-energize motor. With bare fingers and after rotation stops, feel metal spring and retainer of seal assembly. If hot to the touch, pump is cavitating and corrective action should be taken before energizing motor. If seal area is not hot, motor may be energized. Refer to cavitation supplement page and Troubleshooting.

TROUBLESHOOTING

1. Pump does not deliver correct flow and/or head.

Check for:

- a. Pump suction not flooded.
- b. Incorrect rotation.
- c. Driver speed too low.
- d. Suction line restricted.
- e. Plugged suction strainer.
- f. Plugged or damaged impeller.
- g. Poor suction conditions.
- h. Pump or impeller undersized.
- i. Pump cavitation.
- j. Debris lodged into impeller vanes
- k. System resistance too high.

2. Excessive noise or vibration during operation.

Check for:

- a. Motor bearing failing.
- b. Pump cavitation.
- c. Debris lodged into impeller vanes.

3. Leaking mechanical seal.

Check for:

- a. Improper assembly.
- b. Worn or cracked seal faces.
- c. Abrasives in solution.
- d. Crystallization on seal components.
- e. Liquid flashing at seal faces (temp. too high).
- f. Seal pressure rating too low for the service.
- g. Chemical attack on seal parts.
- h. Seal operated dry or with a liquid having poor lubricating properties.
- i. Worn motor bearings.
- j. Pump cavitation.
- k. Poor suction conditions.

4. Pump gradually loses pressure and head.

Check for:

- a. Increasing temperature causing cavitation or liquid vaporization.
- b. Suction lift too high.
- c. Air entering suction line.

5. Motor overheating.

Check for:

- a. Excessive flow and amp draw. (Throttle discharge)
- b. Low voltage or frequency.
- c. Motor wired incorrectly.
- d. Bearing failure.

6. Pump overheating.

Check for:

- a. Solution temperature too high.
- b. Debris lodged into impeller vanes.
- c. Closed discharge valve.
- d. System resistance too high.

PUMP SERVICE

Replacing single mechanical seal and/or impeller/ support casing



CAUTION:

Disconnect power to pump before servicing to avoid dangerous or fatal electrical shock hazards.

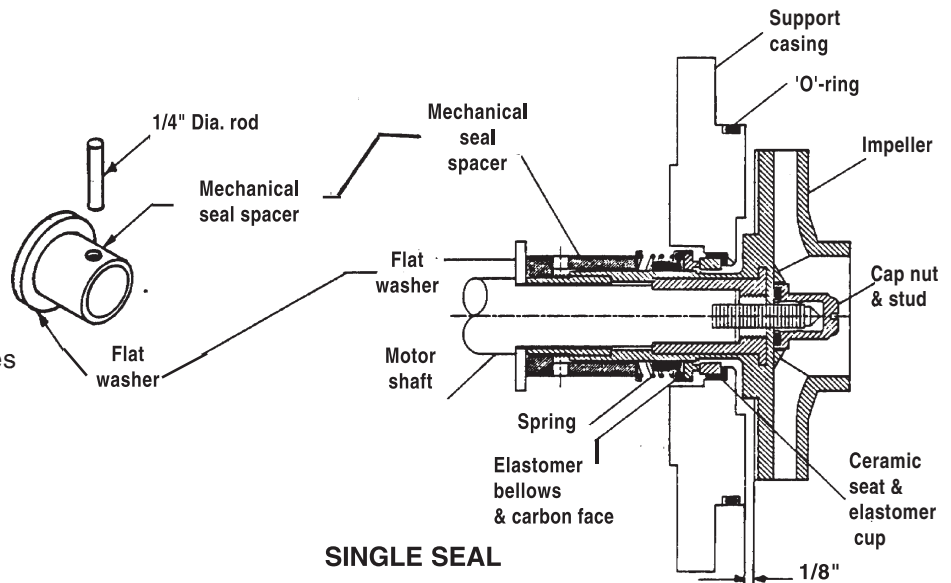

SINGLE SEAL



If pump has been used to pump hazardous materials, be certain that all materials have been removed prior to working on the pump. Inverting pump with liquid in it could cause liquid to get into motor bearings and cause damage. Before disassembling, be certain all liquid is removed from the pump.

1. Removal of suction casing

- a. Remove six bolts that hold the suction casing to the motor connecting bracket.
- b. Thread a 2" x 12" threaded pipe into suction casing inlet, wiggle pipe back and forth until suction casing loosens from support casing.

2. Removal of support casing/impeller assembly

- a. Grasp impeller by hand. Using a 3/4" socket, turn cap nut counterclockwise to remove.
- b. Remove the four bolts located on inside wall of motor connecting bracket. Support casing/impeller assembly will slide off shaft as one unit. If not, remove fan cover and fan from motor. Grasp

the back of the motor shaft with vise grips or pipe wrench. Insert a 1/2"-13 x 3" hex head bolt into the impeller (Where the cap nut was removed). Turning bolt clockwise will separate impeller from motor shaft. Replace fan and cover.

3. Removal of impeller and seal

- Remove seal spacer from impeller by turning counterclockwise. Remove washer and spring. (discard)
- If seal spin or slight dry run has occurred, it will be difficult to slide seal bellows over impeller sleeve. Block up support casing in an arbor press (2 x 4 or similar) and push impeller through support casing. It will help with removal to break bellow-retaining ring with a chisel. If servicing only to replace seal, lubricate impeller sleeve and bellow generously with liquid soap. Place end of impeller sleeve on table. Grasp the support casing by the outer edge and push the impeller sleeve through the seal bellow.
- Remove ceramic seat from support casing using a punch to knock out of counterbore.
- Wash all reusable parts.

4. Installing impeller and seal

- Lubricate elastomer cup and counterbore of support casing with a lubricant (propylene glycol, glycerine, pac-ease rubber lubricant, distilled water). Keep oil from contacting elastomeric parts. Place elastomer cup into bottom of support casing (lapped side facing up). Press into place using a plastic pipe or a block of wood. Check for squareness. Elastomer cup must seat flat against support casing. Wipe off excess lubricant from ceramic face.
- Place the SERFILCO installation tool on a table with the single side up (shallow end up). Place bellow assembly in tool with carbon face up. Make sure no debris is on face. Place support casing on top of tool so the carbon faces the ceramic seat. Place a 1/8" spacer on each side of the hole on the support casing.
- Wrap threads on impeller sleeve with thread sealant tape. Lubricate impeller sleeve (see 4-a). Push impeller through support casing until impeller touches the 1/8" spacers. Leaving the 1/8" spacers in place, turn unit over. Remove tool. Place spring, then the washer over the impeller sleeve. Place seal spacer on the washer/spring. Push down until threads start to meet. Grasp support casing and impeller with other hand. Turn as complete unit counterclockwise until threads engage. Turn seal spacer until flush with impeller sleeve.
- Remove 1/8" spacers from unit.

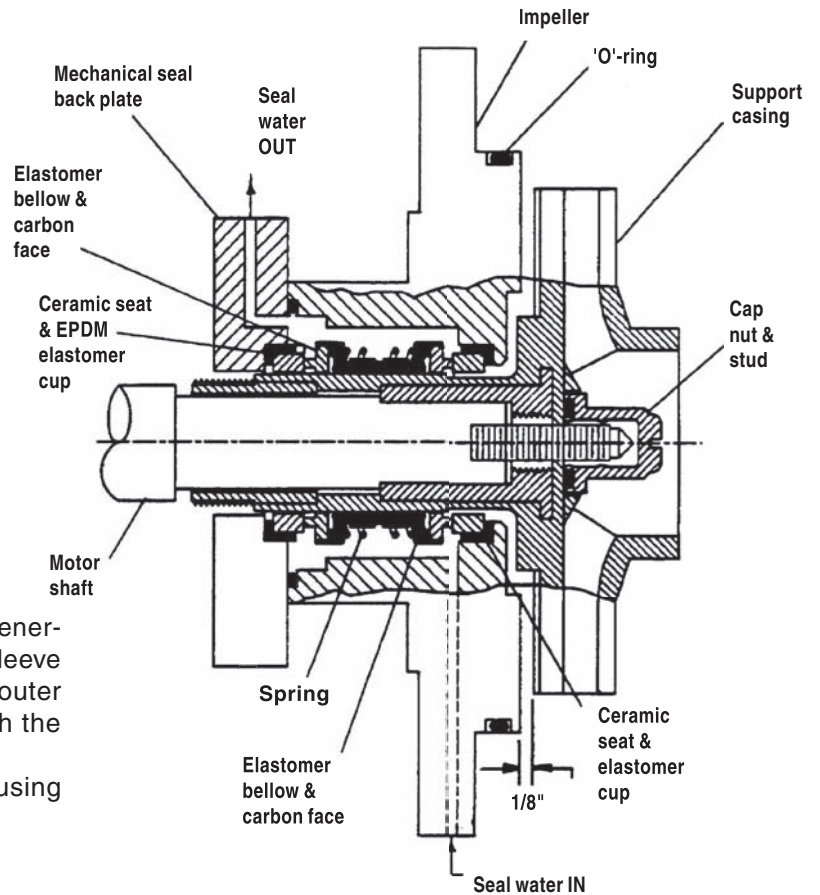

DOUBLE SEAL

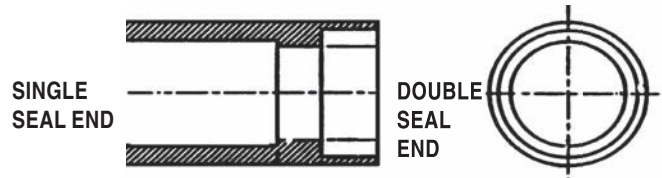

SEAL INSTALLATION TOOL PART NO. 44-2730

5. Installing impeller/support casing unit on motor shaft.

- Check the following:
 - Motor shaft has no corrosive wear. Clean shaft with abrasive cleaning pad if necessary.
 - Flat washer (11-0607) is on shaft.
 - Shaft key is properly inserted in keyway.
- Lightly coat motor shaft with wheel bearing grease. Align keyway inside impeller with key on motor shaft.
- Install cap nut stud with new 'O'-ring into impeller. Do not over tighten. About 55 in-lbs. of torque is recommended.
- Insert a 1/4" diameter steel rod into hole of seal spacer. Hold impeller with hand and turn 1/4" rod until spacer backs up against washer. Note washer must turn with impeller.
- Looking at the support casing, note the two flats. One is tapped 1/8" NPT, one is not. Place the flat that IS

NOT tapped to your upper left. Place one of the four 5/16"-18 x 1" bolts with lock washer through inside wall of the motor connecting bracket into support casing. DO NOT TIGHTEN.

6. Installing suction casing

- Lubricate 'O'-ring and counterbore of suction casing with a lubricant described in section 4-a.
- Fasten suction casing to motor connecting bracket with six bolts and flat washers in an alternating pattern evenly bringing suction casing to support casing. DO NOT OVER TIGHTEN.
- Place the other three 5/16"-18 x 1" bolts with lock washer through inside wall of motor connecting bracket into support casing and tighten bolts.

Replacing double mechanical seal and/or impeller/support casing

7. Removal of suction casing and impeller/support casing assembly

- See Sections 1-a through 2-b of Pump Service.

8. Removal of mechanical seal back plate.

- Before removing the four 5/16"-18 x 2-3/4" bolts, mark the location of the back plate. This will help when reassembling. Location of the back plate outlet is very important.

9. Removal of impeller and seal.

- If seal spin or slight dry run has occurred, it will be difficult to slide seal bellow over impeller sleeve. Block up support casing in an arbor press (2 x 4 or similar). Screw a 1/2"-13 x 6" bolt through impeller sleeve and push impeller through support casing.
- Remove ceramic seats from support casing and back plate using a punch to knock out of counterbores.
- Wash all reusable parts.

10. Installing impeller and seal.

Note that the seals are marked for identification. Green is for Viton, EPDM is not marked.

- See Sections 4a & 4b of Pump Service. Place elastomer cup in back plate in same manner.
- Lubricate impeller sleeve (see 4-a). Push impeller through support casing until impeller touches the 1/8" spacers. Leaving the 1/8" spacers in place, turn unit over. Remove tool. Wipe off excess lubricant from impeller sleeve. Place spring over impeller sleeve. Place second bellow assembly on spring. Make sure the carbon face is facing you. Using the SERFILCO Installation Tool (deep end), push the bellows down until spring is fully compressed. If seal does not stay down, wipe off sleeve with a dry rag. No lubricant residue should be present.
- Lightly lubricate 'O'-ring (22-0567) and place in groove of support casing.
- Line up the mark you made for proper location of back plate outlet (reference step 8-a, if you for

got to do this. Make sure to place the outlet hole of the back plate toward the flat that is opposite the inlet hole of the support casing that is tapped 1/8" NPT). Assemble seal back plate to support casing with four 5/16"-18 x 2-3/4" bolts and flat washer. Place assembly in an arbor press with impeller against a flat surface. Place the SERFILCO Installation Tool on the back plate over the end of the impeller sleeve. Let the arbor come down on top of the tool. DO NOT APPLY FORCE. This will keep the impeller from moving forward when tightening the four bolts. Evenly tighten the bolts until snug. DO NOT OVERTIGHTEN.

- Remove 1/8" spacers.

11. Installing impeller/support casing assembly on motor shaft

- Check the following.
 - Motor has no corrosive wear.
 - Shaft key is properly inserted in keyway.
- Lightly coat motor shaft with wheel bearing grease. Align keyway inside impeller with key on motor shaft.
- Install cap nut stud with new 'O'-ring into impeller. DO NOT OVER TIGHTEN. About 55 in-lbs. of torque is recommended.
- Looking at the support casing, note the two flats. One is tapped 1/8" NPT, one is not. Place the flat that is NOT tapped to the upper left of the motor connecting bracket. The flat that is tapped 1/8" NPT (inlet) should be located to the lower right side of the motor connecting bracket and the outlet of the back plate should be located on the left side of the motor connecting bracket on a horizontal plane. This is very important. Back plate outlet discharge must be on top or an air pocket will form causing seal to heat up and fail.
- Place one of the four 5/16"-18 x 1" bolts with lock washer through inside wall of the motor connecting bracket into support casing. DO NOT TIGHTEN.

12. Installing suction casing

- See Section 6-a of Pump Service.

Installing Pre-assembled Repair-Pac

13. Installing single seal

- See Sections 1-a through 2-b and 5-a through 6-c of Pump Service.

14. Installing double seal

- See Sections 1-a through 2-b, 11-a and 5-a through 6-c of Pump Service.

To replace motor

Follow sections that apply to removal and reassembly of appropriate support casing/ impeller assembly (single or double).

CAVITATION OR 'STARVATION' OF SINGLE MECHANICAL SEAL SERIES 'HE' PUMPS

Dry operation and cavitation can cause seal failure in an identical manner, "burning" of plastic seal plate. It is the duration of these operating conditions which determines the degree of burning. **A charred impeller sleeve** is the result of short duration of dry operation or cavitation. **A charred impeller sleeve and charred seal support plate** is the result of longer dry operation or cavitation.

It is imperative that all users are alerted to the conditions which cause cavitation and make sure they are avoided. A pump can operate with some degree of cavitation and apparently not fail.

CAVITATION - STARVATION

A review of the 'HE' pump flow curve shows that for all combinations of flow and TDH, there is a required NPSH. If the "**available**" is less than the "**required NPSH**", the pump will cavitate. This does not necessarily imply that the pump will immediately fail, or that it will not function to **apparent** stated performance. Cavitation means that the pump is operating inefficiently and at less than minimum design conditions. Premature wear or failure can occur and the duration of inefficient operation is not necessarily accompanied by excessive noise and/or vibration.

Cavitation is usually the result of a restricted inlet, such as undersized or long suction pipe or an excess of fittings and flow restrictions on the pump suction line. Conversely, if no inlet restriction, then the pump will perform exactly to the flow curve. Unfortunately it is usually difficult to determine or know if or when a pump is performing "under spec" caused by cavitation because of the difficulty in accurately determining flow and TDH under field conditions. The sound of cavitation is much like pumping gravel.

It has been verified by test that cavitation can cause seal failure within 30 seconds and failure is **identical** to that of dry operation . . . while pumping 50-60 GPM! The restricted inlet is causing limited flow into the pump and a partial vacuum or a "void of solution" now exists at the

seal face. Heat is rapidly generated and radiated from the ceramic-carbon face. Temperatures between the faces and the adjacent plastic reach 450°F. The plastic gets hot and continued operation causes seal failure and charring of the plastic. Note that lowering the pump flow with a valve on the discharge will not affect the pump as being described above.

DAMAGE TO SEAL SUPPORT PLATE

This is caused by the convection of some of the heat which is rapidly generated at the seal face, through the air space to the support plate itself.

DAMAGE TO IMPELLER SLEEVE

Some of the rapidly generated heat at the seal face is transmitted by convection from the face to the impeller sleeve.

DRY OPERATION

When the pump has been operated dry or has lost its prime and continues to run, seal failure will occur due to excessively high temperatures generated on the mating carbon and ceramic seal faces. Cause of failure can easily be verified by black charring of the plastic sleeve of the impeller assembly and the plastic around the stationary seal area and distortion at rear of seal support plate. Failure can occur within 30 seconds and the degree of failure is strictly dependent upon duration of pump operation. Trying to stop burning (excessive heat) by liquid cooling will thermal shock the ceramic. This can be seen by a ceramic cracked in 2 - 6 places.

The above problem conditions can be avoided. Refer to pages 1 and 2 of the operating instructions.

Cavitation, starvation or dry run are readily identified by inspecting failed parts. Pumps failing due to these operating conditions are not subject to warranty claims.

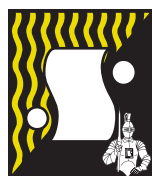

SERFILCO, LTD.

2900 MacArthur Blvd. 847-509-2900
Northbrook, IL 60062-2005 U.S.A. 800-323-5431
e-mail: sales@serfilco.com FAX: 847-559-1995
www.serfilco.com