

# SERIES 'K' PVDF HORIZONTAL CHEMICAL PUMPS

MODEL: 1½ x 1½K

OPERATION AND  
SERVICE GUIDE  
O-810D  
DEC. 1997

Refer to Bulletin P-103 and  
Parts Lists P-7100 & P-9850.

## **!** SAFETY PRECAUTIONS BEFORE STARTING PUMP

1. Read operating instructions and instructions supplied with chemicals to be used.
2. Refer to a chemical resistance data chart for compatibility of materials in pump with solution to be used.
3. Note temperature and pressure limitations.
4. Personnel operating pump should always wear suitable protective clothing: face mask or goggles, apron and gloves.
5. All piping must be supported and aligned independently of the pump.
6. Always close valves slowly to avoid hydraulic shock.
7. Ensure that all fittings and connections are properly tightened.

## **!** BEFORE CHANGING APPLICATION OR PERFORMING MAINTENANCE

1. Wear protective clothing as described in Item 4 above.
2. Flush pump thoroughly with a neutralizing solution to prevent possible harm to personnel.
3. Verify compatibility of materials as stated in Item 2 above.

## **!** IMPORTANT

1. The pump is constructed of PVDF. Clamp and fasteners are 18-8 stainless steel. PVDF may be chemically compatible with the solution being pumped, but care should be taken to protect the pump components against unnecessary wear and physical abuse.
2. Record all model and serial numbers for future reference. Always specify model number and serial number when ordering parts.
3. Pump flow curves are based upon pumping water. Increased motor horsepower may be necessary for pumping other liquids or reduced motor horsepower may be permissible when pumping at higher discharge head.
4. Impellers are designed to offer maximum pump output and the motors are sized for non-overloading at maximum flow conditions. Impellers may be trimmed to reduce flow and discharge head, if desired.
5. Pump inlet piping should be one to two sizes larger than pump suction size.
6. Review Parts List P-7100, and maintain an emergency inventory of replacement items to assure that pump is returned to service with the least delay.

## PRE-START-UP

1. Verify that operating temperature is not in excess of pump design temperature: 190°F maximum.
2. Mechanical seal components which contact the liquid are the carbon and ceramic faces, Viton® bellows and

seat cup. Casing "O" ring is Viton. Verify materials and solution compatibility.

3. Connect electrical supply to motor starter. If starter is furnished, verify that starter and motor are wired for the correct operating voltage and correct overload heaters. It is recommended that a motor starter be installed for overload protection if one was not provided with the pump assembly. Single phase motors are equipped with an automatic thermal overload.
4. Wire for counterclockwise rotation when facing pump suction. DO NOT start a motor to check rotation before liquid is in the pump body. Dry rotation of the mechanical seal can cause immediate failure of the seal components. If pump rotation is incorrect, the motor should be stopped and properly wired. Incorrect rotation will cause an extreme reduction in flow rate. Discharge head could also cause the impeller to unscrew.
5. All units are factory tested to meet published or specified flow rates and to confirm that the seal assembly functioned properly at time of shipment.
6. Install a strainer on the pump suction to prevent foreign material from entering the pump and possibly causing impeller damage. The pump is constructed of PVDF for chemical resistance and does not have the shock resistance of metal.
7. Do not over-tighten suction and discharge connections to the pump body. To prevent leakage at these points, it is suggested that TFE tape be used on the threads rather than a pipe compound.
8. Pump suction is 1½" NPT and discharge is 1½" NPT. The suction pipe or hose should never be smaller than the suction port size and, where maximum flow is desired, pipe sizes should be at least one size larger. Suction pipe velocities should be as low as possible. An increase in suction pipe size will accomplish this. Suction pipe or hose should be as short and straight as possible with a minimum of pipe fittings. This is especially true when liquid being pumped is above ambient temperature. Refrain from using elbows or tees at the suction port. Using pipe or hose smaller than the suction port size increases the velocity of the fluid and friction loss in the suction line.
9. Adjust pump discharge direction by loosening "T" handle on V-retainer coupling. Discharge must be within the 9 o'clock and 12 o'clock positions to prevent air entrapment in the pump casing which could cause priming difficulty and premature seal failure.
10. Support casing yoke must always be at horizontal position to allow solution to drain in the event of seal leakage.

## START-UP

1. Refer to Figure 1. Liquid level is above pump and pump suction connected to side of tank. It is not necessary to prime the pump since liquid will always be in the pump. **IMPORTANT**, a valve located between tank and pump will facilitate pump servicing but it is absolutely necessary that the valve must always be fully open when pump is operating.
2. Refer to Figure 2. Liquid level is above pump and pump suction line goes over the side of the tank. It is now necessary to prime the pump. If piped in place, liquid for priming may be introduced through the discharge line. If hose connected, liquid for priming may be introduced through the suction hose. Be sure that air is not trapped in the hose. Fill hose to overflowing, place hand over open end of hose and submerge into tank. Start motor and wait a few moments before removing hand. If a valve is used on the discharge line, keep it closed until motor has been run momentarily. Open the valve slowly, eliminating all air in line.
3. Refer to Figure 3. Pump mounted above liquid level. It is recommended that a vertical check valve or foot valve be installed in pump suction. Solution can then be poured into suction line by removing plug in suction tee or by pouring into discharge line. Before pump is started, the entire suction line and pump body must be filled with liquid.

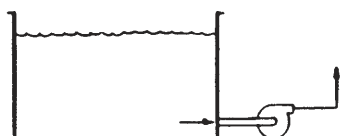

Figure 1

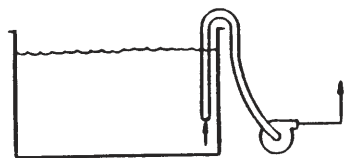

Figure 2

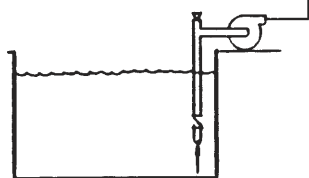

Figure 3

## TROUBLESHOOTING

1. **MOTOR STOPS:** Check for correct voltage, wiring and proper overload heaters in motor starter. Take an ammeter reading at operating conditions and compare to value shown on motor nameplate. Measured value should be equal to or less than rated value. Check for friction free rotation of pump by manually turning fan blade.
2. **PUMP DOES NOT DELIVER CORRECT FLOW:** Check suction strainer and pump inlet to be sure both are not plugged with debris. Compare required flow conditions to original specifications and pump curve which is based on water. Check motor running direction. It should be clockwise from motor fan end.

3. **FREQUENT SEAL FAILURE** can be caused by the following: Abrasives in solutions, crystallization on seal components, chemical attack on seal components (see available alternates), improper priming and pump operation while dry, pump sucking air or undersized suction piping causing cavitation and vibration. Worn motor bearings or bent pump shaft may also be causes of failure. Always flush pump with clean liquid after pumping solutions that could crystallize during pump shutdown.
4. Review parts list and maintain an inventory of recommended spare parts for replacement. This will assure that the pump is returned to operation with minimum delay.

## PUMP SERVICE - See Figure 4

1. **TO REMOVE SUCTION CASING:** Unscrew tee handle on V-retainer coupling until cross pin can be lifted out of its seat. Remove coupling by expanding and lifting it off its seat. Place it on the suction casing which can then be removed. If this component is piped in place, it will be necessary to unbolt the motor from the mounting plate. Disconnect the motor wiring and pull the motor from the assembly. Piping should be loosened at the closest union.
2. **TO REMOVE IMPELLER:** Suction casing must be removed first. Insert channel lock pliers or a #7 vise pliers into opening of support casing to hold motor shaft from turning. Remove impeller by turning counterclockwise. Ceramic seat and Viton bushing, part of the mechanical seal, will be removed with the impeller assembly.
3. Replacement seal assembly is (M2) or (M3). The (M3) is

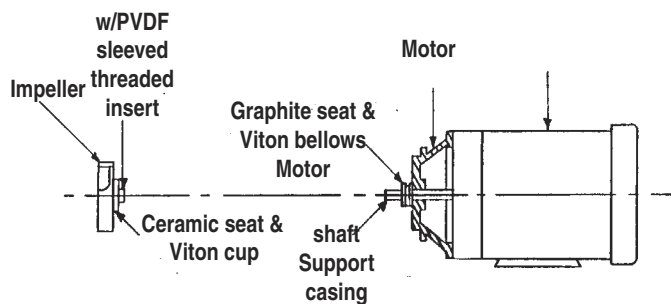

FIGURE 4

4. **TO REPLACE MECHANICAL SEAL:** Remove suction casing and impeller. The Viton bellows are seated in the support casing and can be removed by inserting a small screwdriver blade between the seal and the counterbore in the support casing and gently prying out the mechanical seal. Remove ceramic seat and bushing from impeller. Install new ceramic seat and bushing on the sleeved insert, flush with the back of the impeller. Lubricate sides of Viton and insert into counterbore of support casing.

silica free ceramic and recommended for use with fluorides.

It may be necessary to use the thumbnails to press seal to bottom of counterbore. Lightly lubricate the ceramic and graphite faces. Be careful not to scratch the lapped faces of the ceramic and graphite. Install impeller by holding motor shaft and turning impeller until it seats. Note: Check condition of suction casing "O"-ring and replace if necessary.

5. TO REPLACE MOTOR: Follow steps 1 and 2. Remove support casing from motor by removing the (4) 3/8" bolts. Reassemble pump on new motor. Support casing yoke must be at horizontal position to allow solution to drain in event of seal leakage.

## CAVITATION OR 'STARVATION' OF SINGLE MECHANICAL SEAL SERIES 'K' PUMPS

Dry operation and cavitation can cause seal failure in an identical manner, "burning" of plastic seal plate. It is the duration of these operating conditions which determines the degree of burning. **A charred impeller sleeve** is the result of short duration of dry operation or cavitation. **A charred impeller sleeve and charred seal support plate** is the result of longer dry operation or cavitation.

It is imperative that all users are alerted to the conditions which cause cavitation and make sure they are avoided. A pump can operate with some degree of cavitation and apparently not fail.

### CAVITATION - STARVATION

A review of the 'K' pump flow curve shows that for all combinations of flow and TDH, there is a required NPSH. If the "**available**" is less than the "**required NPSH**", the pump will cavitate. This does not necessarily imply that the pump will immediately fail, or that it will not function to **apparent** stated performance. Cavitation means that the pump is operating inefficiently and at less than minimum design conditions. Premature wear or failure can occur and the duration of inefficient operation is not necessarily accompanied by excessive noise and/or vibration.

Cavitation is usually the result of a restricted inlet, such as undersized or long suction pipe or an excess of fittings and flow restrictions on the pump suction line. Conversely, if no inlet restriction, then the pump will perform exactly to the flow curve. Unfortunately it is usually difficult to determine or know if or when a pump is performing "under spec" caused by cavitation because of the difficulty in accurately determining flow and TDH under field conditions. The sound of cavitation is much like pumping gravel.

It has been verified by test that cavitation can cause seal failure within 30 seconds and failure is **identical** to that of dry operation . . . while pumping 50-60 GPM! The

restricted inlet is causing limited flow into the pump and a partial vacuum or a "void of solution" now exists at the seal face. Heat is rapidly generated and radiated from the ceramic-carbon face. Temperatures between the faces and the adjacent plastic reach 450°F. The plastic gets hot and continued operation causes seal failure and charring of the plastic. Note that lowering the pump flow with a valve on the discharge will not affect the pump as being described above.

### DAMAGE TO SEAL SUPPORT PLATE

This is caused by the convection of some of the heat which is rapidly generated at the seal face, through the air space to the support plate itself.

### DAMAGE TO IMPELLER SLEEVE

Some of the rapidly generated heat at the seal face is transmitted by convection from the face to the impeller sleeve.

### DRY OPERATION

When the pump has been operated dry or has lost its prime and continues to run, seal failure will occur due to excessively high temperatures generated on the mating carbon and ceramic seal faces. Cause of failure can easily be verified by black charring of the plastic sleeve of the impeller assembly and the plastic around the stationary seal area and distortion at rear of seal support plate. Failure can occur within 30 seconds and the degree of failure is strictly dependent upon duration of pump operation. Trying to stop burning (excessive heat) by liquid cooling will thermal shock the ceramic. This can be seen by a ceramic cracked in 2 - 6 places.

The above problem conditions can be avoided. Refer to Page 1, Pre Start-Up Instruction No. 8.

**LONG-COUPLED 'K' PUMP  
w/CAST IRON BEARING PEDESTAL and  
23½" x 10" x 2¾" FIBERGLASS REINFORCED CHANNEL BASE**

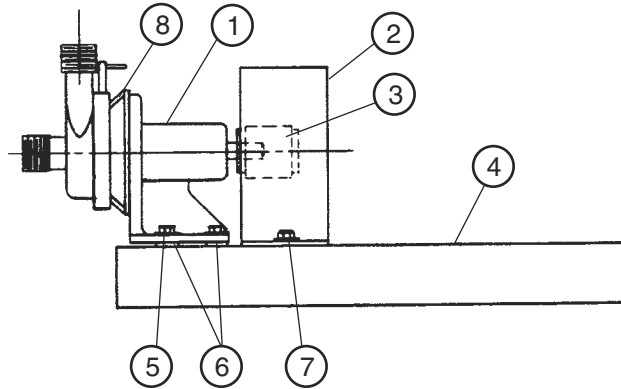

MODEL	FRAME	PRICE CODE NO.
LCK6	56	42-0216
LCK7	143T & 145T	42-0217

**LONG-COUPLED 'K' PUMP  
w/PLASTIC BEARING PEDESTAL and  
18" x 8" x 2¼" FIBERGLASS REINFORCED CHANNEL BASE**

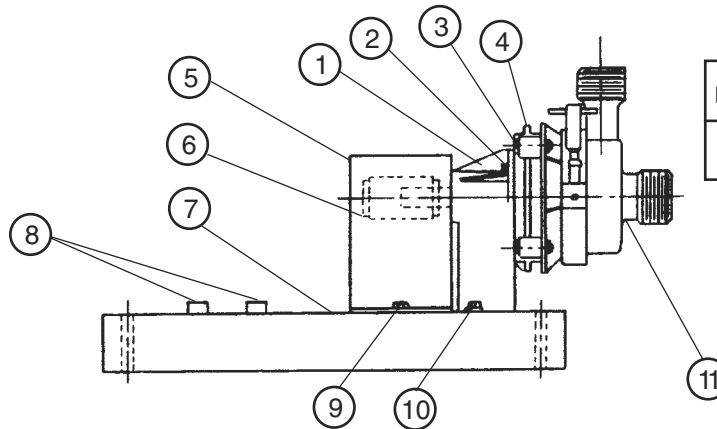

MODEL	FRAME	PRICE CODE NO.
LCK6	56	42-0207A
LCK7	143T & 145T	42-0208A

1. For part numbers and description, refer to parts list P-9850.
2. Factory mounted motor will be aligned and tested before shipment. Verify true alignment and that coupling and all bolts are tight prior to priming pump and energizing motor.
3. Motor mounted by user must be properly aligned to pump. Pump must be primed before motor is energized.

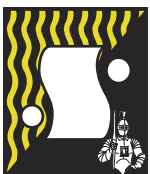

**SERFILCO, LTD.**

2900 MacArthur Blvd. 847-509-2900  
Northbrook, IL 60062-2005 U.S.A. 800-323-5431  
e-mail: sales@serfilco.com FAX: 847-559-1995  
www.serfilco.com