



pH CONTROLLER

OPERATION AND
SERVICE GUIDE
0-720B
APR. 2004

MODEL	PRICE CODE NO.
440	56-045

GENERAL INFORMATION

Model 440 pH Controller is intended to turn power on or off to a pump or valve whenever the pH of the solution being monitored exceeds a set limit. Power outputs are available to turn on with either increasing or decreasing pH.

A complete installation will consist of an electrode to measure the pH of the solution being monitored. In addition there will be the controller and the neutralization system. This will consist of a tank to hold the acid or alkaline solution. Solution flow will be controlled by a valve or pump. This solution will be mixed with the material being controlled. The mixing is usually done in a tank or pit with thorough stirring. The electrode measures the pH of this mixing tank.

The instrument is housed in an aluminum case with all of the controls on the front panel. The meter at the top indicates the pH of the solution being controlled. The CALIBRATION knob is used to calibrate the electrode. The TEMPERATURE knob is for compensating the effect of temperature on the electrode. One (or two) knobs labeled pH set the pH at which the control relay will operate. Electrode connections are on the bottom of the cabinet cover. Power connections are on a terminal strip inside the case.

The dual controller option has several uses. The second control point may be used for an overrange alarm. If the solution being controlled may swing both acid or alkaline, two separate neutralization solutions may be added, to control the pH within a selected range. As an alternative, the two limit controller can be used to add neutralization solution at two different rates which will provide a degree of proportional control. The latter arrangement is valuable when there are large fluctuations in the amount of material to be neutralized. If this option is used with a pump which has a reversible motor driven rate control, a very wide range of neutralization solution addition rates can be accomplished while maintaining the pH in a narrow range. The instrument itself consumes 20 watts of 115 volts AC power. It will operate reliably over a range of 100 to 130 volts. The maximum load is 5 amps resistive or a 1/6 HP motor.

INSTALLATION

The controller may be panel or wall mounted. For panel, make a cutout as shown in drawing. Wall mounting is done by drilling holes in the rear of the instrument case.

To install the instrument, first remove the rear cover. It is retained by the four binding head screws located near the top and bottom of the front panel. After removing the screws, the cover can be lifted over the interior parts. The front panel with the electronics can be completely removed from the cover by removing the two retaining screws for the electrode connectors and loosening the screws for the terminal strips.

If power is to be brought in through a conduit, remove the power cord. At the left end of the terminal block there are two sets of terminals marked ALK, COMM and ACID. These are the output terminals from the relay. If the instrument has one set point control knob, both sets of output terminals are connected to the same relay. If the instrument has two set point control knobs, the right knob controls the right set of ALK, COMM, and ACID terminals and the left knob controls the left set of ALK, COMM and ACID terminals. If acid is to be added, connect the control valve or pump to the COMM and ACID terminals. If alkali or base is to be added, connect the control valve or pump to the COMM and ALK terminals.

In some applications it may be desirable to have a switch between the controller and the pump or valve. This should be added during the installation if there may be a need to obtain a pH reading without the controller operating the pump or valve adding neutralization material.

Select the optimum point for monitoring the solution pH. This will be the electrode location. If a tank is being controlled, the electrode location must be typical of the composition of the entire tank. If a stream is being controlled, all of the stream or a representative portion of the stream must flow past the electrode. Successful pH control will require adequate mixing of the solution before it reaches the electrode. The addition point for the neutralization solution must be selected to provide such mixing before the solution reaches the electrode. For a tank, it is generally necessary to have a propeller type mixer or a circulating pump. The maximum rate at which neutralization material can be added will depend on the speed of mixing.

Mount the electrode so it will always have the junction for the reference as well as the glass electrode under the solution surface at all times. Excessive neutralization material may be injected if the electrodes are out of the solution and cannot present the correct signal to the controller. Support for the electrode should be arranged so the electrodes may be easily removed for cleaning. Since the electrode cable is only 30 inches in length, an extension cable is usually required. Make certain the electrode connector cannot become grounded or the pH reading will not be correct. This connector is at a slightly different voltage from the ground due to the voltage generated by the reference electrode. BNC Extension Cable is available in any length to 100 ft., which is the maximum recommended. If constructed by the user, the cable should be of RG-174/U type. If there is a separate reference electrode in the system, a Pin Jack to Pin Plug Cable is available. Refer to Accessories in **SERFILCO** Catalog.

Neutralization solution may be supplied from a pump or gravity fed from a tank through a solenoid valve. In either case it should be possible to regulate the flow if precise control of the pH is desired. Many different types of metering pumps are available which have adjustable stroke length, period between strokes or motor speed. If gravity feed is used, a needle valve should be near the solenoid valve to control the flow rate. Adjustable rate solids feeders are available from several manufacturers. If the pump or feed mechanism requires more power than this instrument is capable of handling, a heavy duty electrical contactor will be required.

A waste treatment system generally consists of a pit with dividers to promote mixing or a series of pits with dividers. The first pit or section of a pit has a motor driven stirrer and an overflow weir to the next pit or compartments. This first pit or section must be large enough to hold a several minutes supply at maximum rate of flow of the material to be neutralized. The larger the pit, the better the pH control. The next pit or baffled section forces the solution under the baffle. The waste then flows out of the third compartment over another weir and drops into the final compartment or pit. The drain leaves through the wall of this final compartment or pit. The pH controller monitors the first pit or pit section and neutralization material is added at this point. Regulations may require a record of the waste being discharged to the sewer. A Model 400 pH Recorder will generally satisfy this requirement. For some applications, a single very large well-stirred pit is adequate for the waste treatment system.

Design of a system to control the pH of a flowing stream is more difficult. Generally a proportional neutralizer feed system is necessary. This requires a variable flow pump or motor driven valve for a gravity system. The dual controller option will establish high and low limits for pH and drive the control system to inject the correct neutralizer flow rate.

OPERATION

Make certain all connections are complete for power, pump (or valve) and electrode(s). Start the mixer for the solution to be controlled and after a few minutes turn on the instrument. Before turning on, set the temperature knob to the solution temperature. Set the pH control knob to the pH at which the pump should turn on.

Either of the following two procedures may be used for calibrating the electrode. The voltage produced by different electrodes at a fixed pH such as 7.00 is slightly different. Consequently, the electrodes must be calibrated against buffer solution. One procedure is to dip the electrode tip into the buffer and adjust the calibration knob until the meter reads the pH of the buffer. The other procedure is to calibrate a portable pH meter (such as Model PA-10A or PA-11) with buffer. The pH of the solution being controlled is then measured with this meter and the calibrating knob of the controller is adjusted to make the controller read the pH found with the portable meter.

When a new system is first started, it will be necessary to watch the pH meter of the controller for several cycles of the control relay. The purpose of this monitoring is to determine the correct flow rate of the neutralization solution. The flow rate should be adjusted so the pH overshoot on either side of the control point is approximately the same. This will minimize consumption of neutralization material

and produce the most consistent pH for the effluent. In some applications it is only necessary to prevent the pH from going beyond a selected limit. For this, the flow rate of neutralization material may be far more than necessary and overshoot in one direction is acceptable.

ELECTRODES

There are several types of electrodes available from **SERFILCO** (refer to ACCESSORIES). A combination electrode is generally furnished with the instrument. A combination electrode has both a glass pH sensitive electrode and a reference electrode in one all glass unit. Separate glass and reference electrodes are for samples with problems such as high pressure or temperature.

The glass electrode produces an output voltage dependent on the pH of the solution on the outside of the electrode. The pH sensitive portion is a thin glass membrane with a spherical surface on the end of the electrode. Inside this bulb is a silver wire coated with silver chloride and buffer solution between the wire and the thin glass bulb. The amount of voltage produced depends not only on the pH but also on the temperature.

Calomel Reference Electrode

A calomel reference electrode must be kept filled with pure potassium chloride solution. Do NOT use filling solution containing silver or the electrode may be permanently damaged.

There are several reasons for selecting a calomel reference. This is the most stable type of reference available. There is little effect of flow on the junction whereas a silver reference may change its output by as much as 0.2 pH from a no flow condition to a flow rate of a few feet per second past the junction. The presence of certain materials such as proteins or heavy metal ions may cause significant calibration drift of a silver chloride reference, but they have no effect on a calomel reference. If a calomel reference is allowed to run dry, a bubble may enter the calomel cell and the electrode will cease to put out a stable signal. This bubble can only be removed by pulling a vacuum on the electrode and this is a laboratory procedure.

If the relay contacts become worn, it should be replaced.

The relay is a standard type available from several manufacturers. A replacement unit should have a 12 volt coil with at least 75 ohms resistance. A Guardian 1245-2C-12D is recommended.

If the pH set point control knob is removed, it should be returned to a position so its calibration matches the meter. With the instrument turned on, turn the knob until the relay turns on (pump or valve operates). Without turning the knob shaft, loosen the knob set screw and fasten the knob in place with the pointer at the pH on the meter.

If the temperature knob is removed, returning it to the shaft requires an electrical calibration procedure. The temperature control knob determines the change in meter reading produced by a change in the input voltage. To set this knob it will be necessary to have a precise 0.414 volt source. With the instrument input shored, set the meter to 7.00 with the calibration knob. With +0.414 volts DC injected into the BNC connector, turn the temperature control shaft until the meter reads 0.00 pH. Attach the knob so the pointer indicates 25°C.

BUFFER SOLUTIONS

Buffer solutions for calibrating the electrode are available from **SERFILCO**, or may be prepared from the instructions provided in many chemical handbooks. For best test accuracy, the buffer pH should be as close as possible to the sample pH. Buffer solution pH may change with time due to absorption of carbon dioxide. Solution stored in plastic bottles for more than a year should be suspect and checked against fresh buffer. Deterioration is greatest for high pH buffers such as borate.

All buffer solutions change pH with a change in temperature. The pH of buffer solutions vs. temperature is shown below:

Temperature °C	pH 1.68 tetroxalate	pH 4.01 phthalate	pH 7.00 phosphate	pH 9.18 borate
0	1.67	4.01	7.12	9.46
5	1.67	4.01	7.09	9.39
10	1.67	4.00	7.06	9.33
15	1.67	4.00	7.04	9.27
20	1.68	4.00	7.02	9.22
25	1.68	4.01	7.00	9.18
30	1.69	4.01	6.99	9.14
35	1.69	4.02	6.98	9.10
40	1.70	4.03	6.98	9.07
45	1.70	4.04	6.97	9.04
50	1.71	4.06	6.97	9.01
55	1.72	4.08	6.98	8.99
60	1.73	4.10	6.98	8.96
70		4.12	6.99	8.92
80		4.16	7.00	8.88
90		4.20	7.00	8.85

Sample pH will also change with temperature depending on the composition. For accurate results, it is important that buffer and sample be at the same temperature. Conversely, if an accuracy of only 0.2 pH is required, buffer pH drift with temperature generally may be ignored.

MAINTENANCE

At weekly intervals, the filling solution level in the reference electrode should be checked. If a flow or immersion assembly is being used, the filling solution level need be checked only once a month. If the sample is oily or has a large amount of suspended solids the glass pH bulb and the junction should be thoroughly wiped with a wet paper towel.

Periodically the temperature of the solution being neutralized should be tested to determine if the temperature compensation knob is set correctly. The change in output voltage with change in pH is temperature dependent for an pH electrodes. The effect is known with high accuracy and can be accurately compensated. If the instrument is calibrated within one pH of the set point and the temperature does not change more than 20°C, the error from temperature will be less than 0.1 pH. Consequently for many applications careful monitoring of temperature is not necessary.

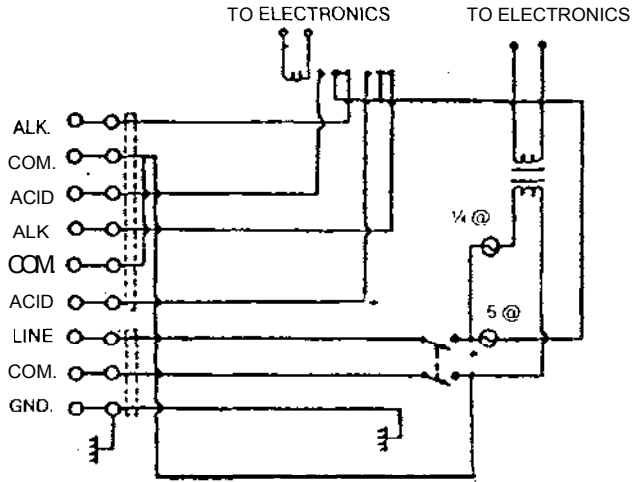

SINGLE CONTROL POWER CIRCUIT

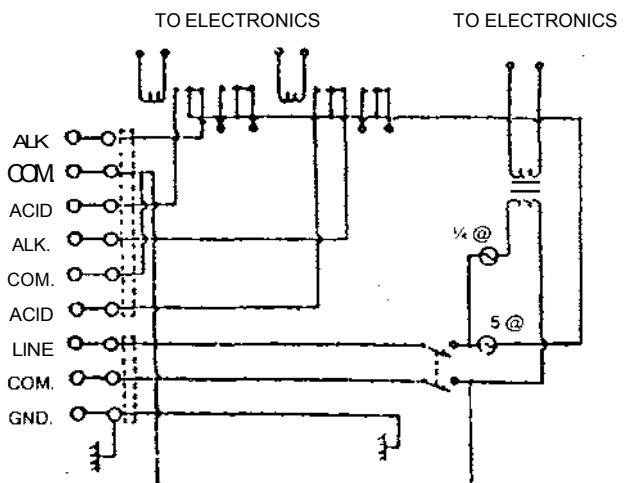

DUAL CONTROL POWER CIRCUIT

ACCESSORIES

Refers to Master Price List F-700

OPTIONS FOR USE WITH MODELS 440,400,430,432		
Item and Description	Applicable to Model Nos.	Price Code
CONTROL OPTION - Includes a second DPDT relay and a second set point control. Valuable when adding two solutions.	440, 430,432	56-200 56-201
DUAL CONTROL OPTION - Specify this option when second set point is to be wired to the Recorder useful as an alarm or to control the addition of a final neutralization treatment.	432	56-202
DUAL CONTROL OPTION - Specify this option when second set point is to be used as an overrange safety shut-off. In the event fouling of the electrode poses a problem, the recorder set point is connected in series with the controller set point. The recorder set point is then adjusted 1 or 2 pH units beyond that of the controller.	432	56-203
ADJUSTABLE CYCLE TIMER - A solid state timer which will start timing when the set point is reached. At any preset point between 0 and 99 minutes, the timer will reverse the output relay. This safety feature is designed to stop an acid pump in a closed system in the event of a mechanical or electrode failure.	430, 440, 432	56-204
AUTOMATIC TEMPERATURE COMPENSATOR PROBE	430, 432	56-205
TEMPERATURE COMPENSATOR EXTENSION CABLE	430, 432	56-206
BNC TO BNC EXTENSION CABLE UP TO 100 FEET	430, 432, 440, 400	56-207
REFERENCE ELECTRODE EXT. CABLE	430, 432, 440, 400	56-208
CHART PAPER - 50 divisions. 63 foot roll	400, 420, 432	56-211
INDUSTRIAL GLASS/CALOMEL ELECTRODE - A combination electrode designed to operate for two weeks without refilling. The body has a 50 mm extra length over our standard combination electrodes. This provides an inexpensive reliable means of monitoring waste neutralization pits or cooling towers provided there is less than 4 inch variation in water level. An excellent electrode for recorders and controllers. pH range: 0 to 12 pH. Temperature range: 0°C to 80°C. Guard Diameter: 12mm. Body Diameter: 12mm. Overall Length: 205mm. KC1 Flow Rate: 8ul per hour. Reproducibility: 0.002 pH.	430, 432, 440, 400	56-300
IMMERSION ASSEMBLY WITH REPLACEABLE COMBINATION ELECTRODE & JUNCTION - This assembly is designed for industrial environments and is guarded against weather and mechanical damage. The glass electrode is protected and can be removed for cleaning or replacement. The peripheral junction is removable and can easily be cleaned or replaced. All wetted parts are of chemically resistant CPVC. The BNC connector is protected by a plastic fitting which has one inch pipe thread for connection to a conduit or junction box. Temp range: 0°C to 100°C. pH Range: 0 to 14. pH Connector: BNC. Pressure: 150 psi. Size: 1" O.D. x 3" long. Features: replaceable electrode and ceramic junction. Complete with 10 ft. extension cable.	430, 432, 440, 400	56-301
COMBINATION pH ELECTRODE ONLY w/36' LEAD		56-115
DISPOSABLE COMBINATION - Features both the pH measuring and reference constructed in a single stem for one probe convenience. The sealed reference needs no pressurization or filling during entire probe life. The combination pH electrode is potted permanently into the PVC housing with a 3/4" NPT fitting. Max 6" overall length. pH range 0 - 14. Temp range -5°C to 80°C. Up to 100 psi.	430, 432, 440, 400	56-305
ELECTRODE FILLING SOLUTION - 4M KC1 solution saturated with Ag-AgCL, packaged in a pint bottle. Used in immersion assemblies.	430, 432, 440, 400	56-304
REDOX - ORP PROBE ASSEMBLY - with 5 ft. of 3/4" leads for 56-301 Gland.	430, 432, 440, 400	56-086

**SERFILCO[®], LTD.**

2900 MacArthur Blvd 847-509-2900
 Northbrook IL 60062 800-323-5431
 sales@serfilco.com fax 847-509-1995
 www.serfilco.com