



# BAG FILTER CHAMBER

## MODELS

**1230BFS 1½-G3A**  
**1250BFS 1½-G3A**

Refer to Bulletin C-301 and  
Parts List P-6550.



### IMPORTANT

1. Refer to Bulletin for operating specifications and replacement bags for each style chamber.
2. Read operating instructions and instructions supplied with chemicals to be used.
3. Refer to Chemical Resistance Data Chart for compatibility of materials with solution to be used.
4. Note temperature and pressure limitations on chart.

### START-UP

Attach hose adapter or pipe to 1½" NPT base outlet. Connect inlet hose to cover. Tighten cover by turning tee handles.

### BAG REMOVAL & REPLACEMENT

1. Remove inlet hose on cover by unlatching coupler on quick coupling.
2. Loosen tee handles and allow swing bolts to drop to side of shell. Remove cover.
3. Remove bag from chamber by grasping handles at top of bag and pulling straight up.
4. New bag should be placed through hole in support plate and bag "O"-ring at top is laid in "O"-ring groove of support plate. Hem beyond "O"-ring should be placed down into groove.
5. Put cover on top of chamber and pull swing bolts into CPVC cover slots. Tighten tee handles and connect hose to coupling.
6. Release air from chamber by opening vent valve in cover. Close valve after all air has been expelled.

### FILTRATION TIPS

Bag replacement can be determined by the pressure registered on the pressure gauge. This pressure can be established after some bag replacements or cleanings have been made.

### REPLACEMENT BAGS

Refer to Bulletin.

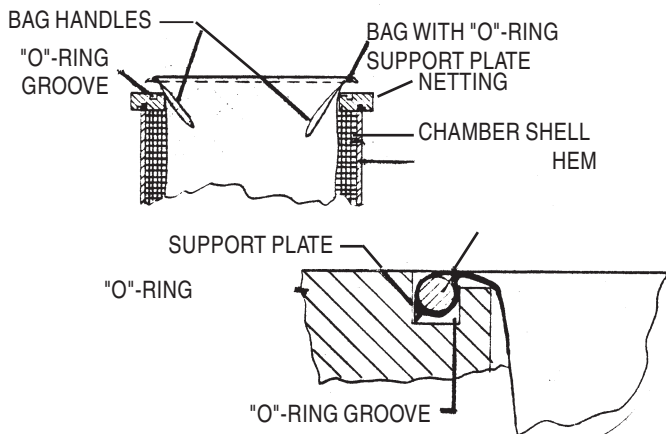

PRESSURE/TEMPERATURE LIMITATIONS DO NOT EXCEED THESE MAXIMUM RECOMMENDATIONS	
MODEL	MAXIMUM
PL-1230 & 1250	80 PSI @ 70°F or 17 PSI @ 120°F
CVL1230 & 1250	80 PSI @ 100°F, 60 PSI @ 200°F

### TO REPLACE LINER FOR CVL MODELS

1. Drain chamber of all solution.
2. Remove cover, adapter plate, polypropylene netting and bag.
3. Remove 4 top ½"-13 hex nuts on hold-down bracket. Lift shell straight up to remove it from the base.
4. Strip vinyl liner from shell. New vinyl liner should be soaked in water at approximately 120°F to make it pliable.
5. Remove hold-down and swing bolt brackets from shell.
6. Put vinyl liner into shell and pull ends over each end of shell. Pull liner as tight as possible but not into bracket grooves.
7. Re-assemble hold-down and swing bolt brackets in shell grooves and put shell back on base. Tighten hex nuts to hold shell to base.
8. Re-assemble cover, adapter plate, bag etc.
9. After filter chamber has been put into operation, check for leaks and tighten hex nuts on hold-down bracket, if necessary.

### TO REPLACE "O"-RING

Follow steps No. 1, 3, 7, 8 and 9 on above instructions.

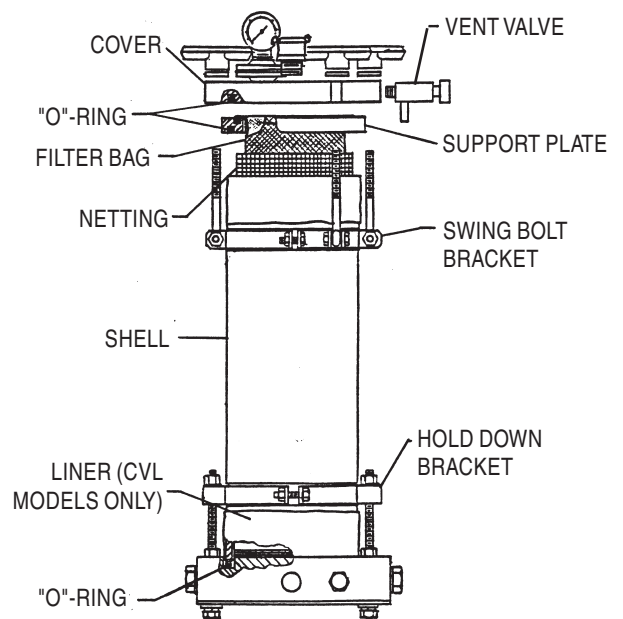

**SERFILCO, LTD.**

2900 MacArthur Blvd. 847-509-2900  
Northbrook, IL 60062-2005 U.S.A. 800-323-5431  
e-mail: sales@serfilco.com FAX: 847-559-1995  
www.serfilco.com