



GUARDIAN FILTRATION SYSTEMS

with MECHANICAL SEAL CPVC or MAGNETIC COUPLED PUMP

OPERATION AND
SERVICE GUIDE
O-220G
DEC. 1999

Refer to Bulletin F-301 and Parts
Lists P-500 & P-5500

DESCRIPTION

The Guardian Filtration System is comprised of a filter chamber, pump-motor assembly (either a mechanical seal or seal-less magnetic drive pump), interconnected piping, flow control valve, slurry tank and/or carbon chamber.

SAFETY PRECAUTIONS **BEFORE STARTING FILTRATION SYSTEM**

1. Read operating instructions and instructions supplied with chemicals to be used.
2. Refer to a chemical resistance data chart for compatibility of materials in pump with solution to be used.
3. Note temperature and pressure limitations of pump and chamber(s).
4. Personnel operating pump should always wear suitable protective clothing: face mask or goggles, apron and gloves.
5. All piping must be supported and aligned independently of the pump.
6. Always close valves slowly to avoid hydraulic shock.
7. Ensure that all fittings and connections are properly tightened.
8. The suction pipe or hose should never be smaller than the suction port size. Pipe sizes should be at least one size larger. Suction pipe velocities should be as low as possible. An increase in suction pipe size will accomplish this. Suction pipe or hose should be as short and straight as possible with a minimum of pipe fittings. This is especially true when the liquid being pumped is above ambient temperature. Refrain from using elbows or tees at the suction port.
9. Siphon breakers in the suction line to the pump and filter discharge to the tank should be installed as a further precautionary measure to limit and minimize the amount of liquid lost by back siphoning. An effective siphon breaker is a 1/4" hole drilled in the suction and discharge lines approximately 2" to 4" below the normal solution level.

BEFORE CHANGING APPLICATION OR PERFORMING MAINTENANCE

1. Wear protective clothing as described in item 4 above.
2. Flush pump and filter chamber thoroughly with a neutralizing solution to prevent possible harm to personnel.
3. Verify compatibility of materials as stated in item 2 of Safety Precautions above.

PRE-START-UP

1. Review accompanying pump, motor and filter chamber Operating Instructions to assure proper start-up and operation.

2. Install a motor starter with proper overload protection if not provided with system.
3. Check power source for correct voltage and phase and make connection to motor starter.
4. Screw into place any valves not installed due to crating. If suction and discharge elbows are used, they may be rotated to obtain proper direction and eliminate hose loops. Suction pipe or hose must be as short as possible and free of unnecessary bends, elbows, etc.
5. Securely fasten hose to hose adapter using metal hose clamps. Tighten clamps. Tighten union connections.
6. Inspect all pipe, fittings, filter chamber and pump for any damage due to shipping.
7. If pump assembly includes double water flushed mechanical seal, immediately connect water line to seal assembly. **DO NOT** start pump without providing water to seal housing.
8. With a single mechanical seal or magnetic coupled pump, no adjustment or water lubricant is required. Refer to pump service for proper pump operation. **DO NOT** start pump without having a flooded pump suction.
9. Check correct direction of rotation by jogging motor. If rotation is incorrect switch any two of the three lead wires in the terminal box or motor starter. Re-check rotation.
10. If the unit is to be installed with piping at the suction, increase to the next larger pipe size. **DO NOT** manifold suction line with other equipment or use any bends right before the pump inlet.

START-UP

BASIC SYSTEM (with valve V1)

Valve V-1 on the pump discharge may be used to control flow rate, maintain prime in pump when changing cartridges, and limit flow from a magnetic drive pump to retain impeller and drive magnet synchronization.

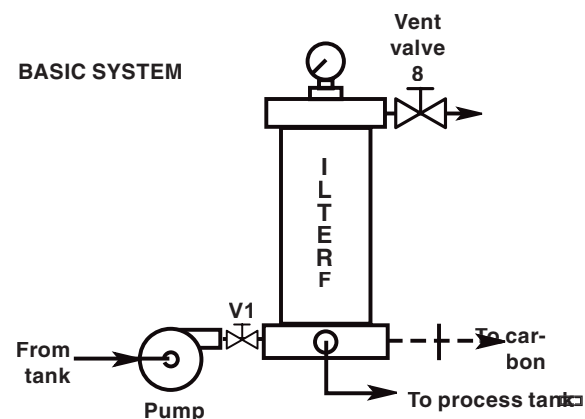

1. Place discharge hose over the side of the tank and secure in place.
2. Unscrew the strainer from the suction hose. Throttle **V1** to approximately 50% open.
3. Hold the discharge and suction hoses and fill with water until the filter chamber is 1/4 full.
4. Shake the suction hose to dispel all air from the hose and pump.
5. Place a gloved hand over the end of the suction hose filled to the top with liquid, immerse in the tank and energize the motor.
6. Secure the suction hose in the tank.
7. Vent the chamber by opening **V8**, then close when solution appears.
8. Replace the suction strainer while the hose is under solution and with the pump off.
9. Turn the pump on and open **V1** fully.

SV4 SYSTEM (Basic plus slurry tank and 4 valves)

1. Priming of the pump is accomplished by using the slurry tank.
2. Place the suction and discharge hoses in the plating tank and securely fasten to the tank. Do not locate the suction hose close to rising bubbles in an air-agitated tank.
3. Close all valves, then open **V1, V4, V3** and **V8**. Fill the slurry tank with water or plating solution. Allow liquid to rise in the filter chamber by having vent valve **V8** open.
4. Start motor. Slowly open suction valve **V5** and close **V4** as solution rises in the slurry tank. Open discharge valve **V2** and close **V3**. Dispel air from the chamber by opening **V8** and closing when liquid vents from **V8**.
5. Note, **V1** must always be wide open when the pump is running.

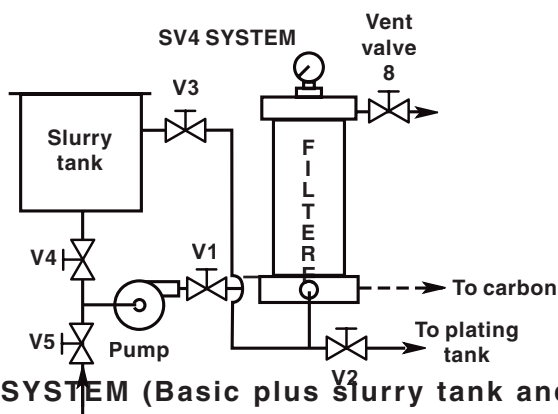

SV7 SYSTEM (Basic plus slurry tank and 6 valves).

1. Priming of the pump is accomplished by using the slurry tank.
2. Place the suction and discharge hoses in the plating tank and securely fasten to the tank. Do not locate the suction hose close to rising bubbles in an air-agitated tank.
3. Close all valves, then open **V4, V3** and **V8**. Fill the slurry tank with water or plating solution. Allow liquid to rise in the filter chamber by having vent valve **V8** open.
4. Start motor. Slowly open suction valve **V5** and close

- V4** as solution rises in the slurry tank. Open discharge valve **V2** and close **V3**. Dispel air from the chamber by opening **V8** and closing when liquid vents from **V8**.
5. Note, **V1** must always be wide open when the pump is running.

TO USE AS A PRECOAT FILTER WITH CARTRIDGES OR SLEEVES

	MODEL					
	240	360	480	600	480 x 2	600 x 2
Lbs. of Filter Aid	2	3	4	5	8	10

Type of filter aid: Diatomaceous earth
Precoat depth cartridge: 15 micron or denser
Precoat sleeve: Sub-micron to 5 micron

TO USE POWDERED CARBON

After precoating with filter aid, a slurry of 2 to 4 oz. (per cartridge) of powdered carbon and filter aid (mixed in equal amounts) may be supplied by following these precoating instructions.

TO PRECOAT BASIC MODEL

Precoating BASIC models is not generally recommended but can be accomplished. Since a separate slurry tank is required along with a certain skill of operation, it is suggested that the factory be contacted for instructions on the proper procedure to follow.

TO PRECOAT MODEL SV4

1. Add plating solution to the slurry tank by opening **V3**. **V1** can be throttled or remain fully open.
2. Open **V4**, close **V5** and **V2**. Solution is now recirculating in the slurry tank.
3. Add filter aid to the tank in amounts shown in the chart.
4. Recirculate solution between the slurry the tank and the filter chamber until solution is crystal clear.
5. Gradually open valves **V2** and **V5**, and close valves **V3** and **V4**. The filter is now operating to the plating tank.

TO PRECOAT MODEL SV7

1. Open valve **V3** to draw solution into the slurry tank or fill the slurry tank with water. Close the valve when the slurry tank is filled. **V1** can be throttled or remain fully open.
2. Gradually open valve **V4** and close valves **V5** and **V2**. Solution is now circulating between the filter chamber and slurry tank.
3. Measure the total amount of filter aid for your model and gradually add it to the slurry tank to permit an even distribution of filter aid to the cartridges. After all filter aid has been applied and an even coat is formed, allow the solution to recirculate until it is clear.
4. Gradually close valves **V3** and **V4** and open valves **V2** and **V5**. The filter is now operating to the plating tank.

TO BACKWASH MODEL SV7

1. Fill the slurry tank with water and open **V4** or place

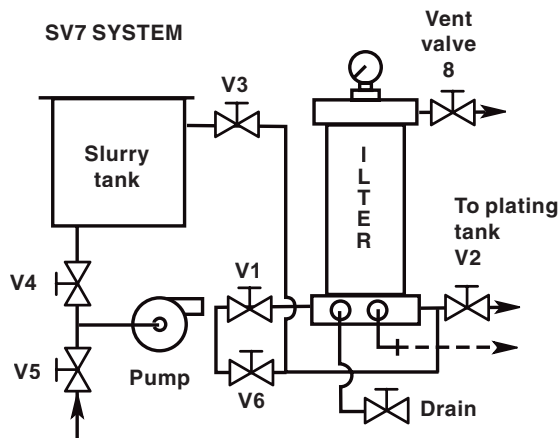

the suction hose in a clean rinse tank and open valve **V5** to purge solution from the filter into the plating tank through valve **V2**. Be sure to close valve **V4** before the pump loses prime.

2. Add additional water to the slurry tank.
3. Close valves **V1**, **V2** and **V8**, open **V6** and **V7** to cause diluted solution and a portion of cake to drain out. Liquid will now flow from the inside of the cartridge to the outside, causing cake to break away and fall. Two to three backwashes of this type will rinse free the remaining cake. Periodically open **V1** to help wash cake out of the drain port.

An alternate method of backwashing is to keep valves **V7** and **V8** closed, open valve **V6**, then quickly open valve **V7**. With a chamber full of liquid, the flow will be from the inside and out of the tube and out of the drain. Density of cartridge, solution, filter aid and experience will determine which backwash method is most suitable.

NOTE: After repeated cycles of filtration, backwashing and precoating, the cartridges will eventually reach a point where they cannot be returned to a like-new condition or high flow rate. Noting initial flow and pressure across new precoated cartridges will help determine when to discard old cartridges.

TO REPLACE FILTER CARTRIDGE

1. Stop the pump and close **V1** to hold prime in the pump.
2. Remove the top separator plate and spring seat assemblies.
3. Grasp the end of the filter and lift straight up to remove from the chamber. Set aside for cleaning or disposal.
4. Insert new filters. Replace the top separator plate, top seat plate and spring assembly. **IMPORTANT:** Note the top separator plate orientation.
5. Replace the cover on the shell and pull the cover down by tightening two diametrically opposite swing bolts only. Tighten the remaining four swing bolts.

OPTIONAL CARBON CHAMBER DESCRIPTION

A carbon purification chamber offers a simple, low cost, effective method of removing organic impurities from plating baths and other chemical solutions. The carbon chamber is in series with the filter chamber which traps particulate matter. The granular activated carbon in the carbon chamber removes the organic impurities. Partial flow of the filtered solution is diverted to the carbon chamber by use of discharge valve **V2** on the filter chamber and controlled by carbon inlet valve **V9**.

System performance should be established to determine optimum adsorbency vs. flow rate relationship.

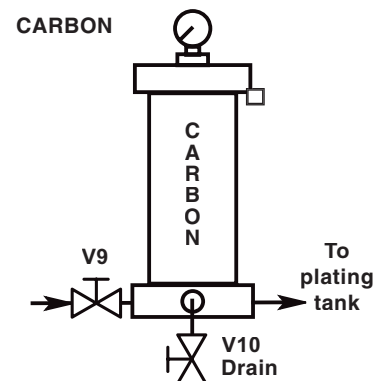

CARBON CHAMBER START-UP

1. Remove the top cover by loosening the tee handles and lifting the cover straight up. Remove the canister from the chamber by grasping the canister at the locking tee cap and pulling straight up.
2. Remove the tee cap at the top of the canister so the cover can be removed. Note the trap filter. Fill each canister with approximately 7 lbs. of activated granular carbon, tap the sides of the shell gently so that the carbon will settle. Replace the canister cover.
3. Lower the canister into the shell and insert the hole in the center pipe over the pipe adapter in the base. There is an "O"-ring seal that will prevent by-passing of solution.
4. Replace the spring on the top of the canister. Place the cover on the shell and tighten the tee handles.

TO REPLACE CARBON IN CARBON CANISTER

NOTE: Be sure that all of the solution has been completely drained out of the chamber and canister before trying to remove the canisters. Failure to drain both the canisters and chamber will result in a loss of solution.

1. Shut off inlet valve **V9** to the carbon chamber. Open drain valve **V10** and allow the canister to drain so that all of the solution is removed.
2. Remove the top cover by loosening the tee handles and lift the cover straight up. Remove the canister by grasping the locking tee cap and pulling straight up.
3. Place the canister on a table or suitable support where the carbon can be conveniently dumped. Remove

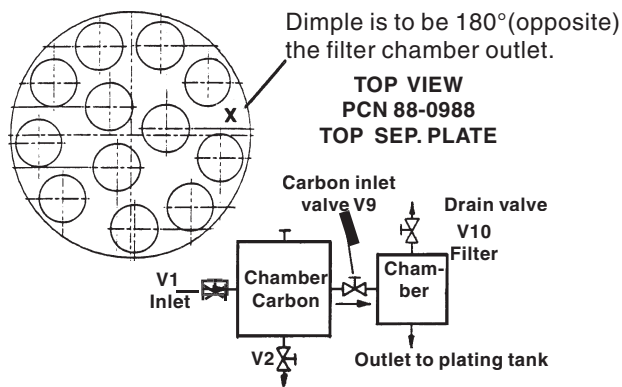

Outlet valve V2 adjust for flow to plating tank Note: schematic on page 2.

- the cap with the tee handle and lift the cover off.
- To replace the trap filter, unscrew the standpipe assembly at the top end of the cartridge which can then be removed and replaced.
 - After replacing the trap filter, place the canister in a vertical position with the top up. Refill the canister as outlined under Pre-Start-Up (below).
 - Lower the canister into the shell and insert the hole in the center pipe over the pipe adapter in the base. There is an "O"-ring seal that will prevent by-passing of solution.
 - Replace the spring on top of the canister. Place the cover on the shell and tighten the tee handles.

PRE-START-UP

- Remove the top cover by loosening the tee handles and lifting the cover straight up. Pour activated carbon into the shell using care not to pour carbon into the percolator tube. Gently tap the sides of the shell so the carbon will settle. Carbon must be below the end of the percolator tube. Reinstall the cover and tighten the tee handles.

START-UP

- Flush the carbon with a volume of water or process solution until the discharge runs clear. Take sample from the outlet to verify the quality of the discharge.
- Open valve **V9** between the carbon chamber and filtration system. Adjust outlet valve **V7** on the filtration system until the desired flow is obtained from the carbon chamber. Bleed air from the chamber by loosening the vent screw on the cover.
- Prior to exiting each chamber, the solution passes through one of 3 filter screens.
- Carbon requires replacement when it no longer has its adsorbency property. Filter screens need replacement when the required minimum flow rate cannot be maintained.

TO REPLACE CARBON IN BULK CARBON CHAMBER (Refer to O-240 for further information)

- Shut off inlet valve **V9** to the carbon chamber. Allow the chamber to drain so that all of the solution has been removed.
- Remove the carbon chamber from the system by

- removing one coupling on inlet valve **V9** between the carbon chamber and filter chamber. Remove the four hex nuts holding the carbon chamber to the base. Lift the carbon chamber off its metal base and place it on a table or similar support where the carbon can be conveniently dumped.
- Remove the cover, exposing the carbon, which can be removed by turning the chamber on its side and dumping the carbon.
- To replace the filter screen, unscrew it from the base.
- Mount the carbon chamber back on the steel base and re-assemble the valve and hex nuts.
- After replacing the filter screen, place the chamber in a vertical position with the top up. Refill the chamber as outlined under Pre-Start-Up.

PURIFICATION TIPS

- By-pass Purification:** The carbon chamber is installed on the filter discharge with valve **V9** on the carbon chamber inlet. Flow through carbon is adjusted to approximately 1 to 5 GPM per each 7 lb. canister. Continuous recirculation by this method should eliminate or significantly postpone batch treatment with powdered carbon.
- Full Flow Purification:** Valve **V2** is closed and valve **V9** is opened to provide suitable flow. A low flow rate will provide optimum adsorbency during transfer.
- A regular analysis of the carbon chamber discharge will establish the ideal flow rate and indicate when carbon replacement is necessary.
- A pressure gauge on the carbon chamber inlet will permit valve adjustment for repeatedly obtaining identical flow rate.

EQUIPMENT MAINTENANCE TIPS

- Keep the overall unit clean and dry and avoid splash ing water on the motor or starter.
- Check seals frequently for leakage and repair immediately when necessary, before the solution which is leaking causes additional damage to the pump or to the motor.
- When the pump requires servicing, it is usually easier to remove the pump from the base of the filtration assembly so that repairs may be made.
 - The CPVC horizontal pump may be best serviced by loosening the four mounting bolts from the motor in addition to the four bolts holding the suction casing in place in the piping.
- Should damage to any of the pipe occur, order replacement assemblies only, rather than the individual components, since all of the piping is socket welded at the factory with the exception of a few screwed connections used between the pump and slurry tank and the hose barbs. You will find that these factory replacement assemblies will fit without additional cutting if ordered by serial number of the system.
- Refer to the parts list to order replacements by part number and keep the suggested parts on hand as indicated on the parts list, so that downtime can be kept to a minimum.
- Keep the cover gasket clean by wiping with cloth before replacing the cover. When replacing the gasket at

the cover or base:

- a. Remove the old gasket and thoroughly clean the gasket groove.
- b. Lubricate top & bottom surfaces of the gasket with soap solution, petroleum jelly or other suitable lubricant.
- c. Insert the gasket into the groove.
- d. Tighten evenly to the shell.
- e. Pressurize the chamber, relieve the pressure and retighten.

PIPE ASSEMBLY SERVICE GUIDE

The following suggestions are offered when servicing the filtration system:

Sometimes solvent sealed piping contains some threaded connections out of necessity. Whenever possible, if pipe has to be removed from the system to service or repair a pump, filter or slurry tank, it is best if the pipe can be removed as a complete assembly. Pipe assemblies can be removed at any valve by removing the union nut at either end of the "true union" valve. The bulkhead fittings in the slurry tank will unscrew from inside the tank. The pump itself splits between the suction casing, which generally includes the inlet and outlet pipe connection, and the support casing which includes the impeller. When ordering pipe assemblies, denote the size of the pipe such as 1½" or 2". Provide the serial number of the Guardian System.

ELECTRICAL

If the motor fails to start or runs at improper speed or stops after several minutes of operation, TURN the MOTOR STARTER OFF. Check the electrical source and compare to the original order. Compare the number to that shown on the inside of the cover on the motor starter box. Check the ampere draw with the motor running and compare with the full load ampere rating on the motor data plate. If greater than the data plate rating, reduce flow from the chamber by throttling discharge valve **V1**.

FILTRATION TIPS

1. Never precoat until the chamber is free of air.
2. The collection of air in the chamber means a loose hose or fittings on the SUCTION side of the pump or that the suction hose has been placed near an outlet on an air agitated tank.
3. After batch carbon treating, dispense an equal amount of filter aid to the treatment tank, agitate, allow to settle. Filter solution back to the tank below the liquid level with the hose held only several inches under the top of the liquid. This allows the maximum flow rate during the transferring cycle.
4. **DO NOT OPERATE FILTER UNATTENDED.** Mechanical seal failure, cracked hose, or some other unforeseen occurrence can result in solution loss or damage to equipment.
5. To prevent solution from accidentally being pumped out of the tank, position the suction hose at a minimum depth below the liquid level. If the filter is piped in place, the suction may be extended to the bottom of the tank if a "vacuum break" hole is provided in the same pipe but below the liquid level. The solution level, when lowered to this point, will cause air to enter the pump suction and cause loss of prime.
6. If the filter media has been precoated, never shut the filter off and start it up without first adding some additional amount of filter aid to make certain that a cake has been redeposited in any areas of the media where it may have fallen away from the support membrane.
- 6a. Add additional filter aid depending upon the amount and type of solids, at periodic intervals so that the outer surface of the filter remains porous and the flow rate will be maintained at its highest level.

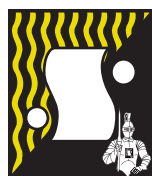

SERFILCO, LTD.

2900 MacArthur Blvd. 847-509-2900
Northbrook, IL 60062-2005 U.S.A. 800-323-5431
e-mail: sales@serfilco.com FAX: 847-559-1995
www.serfilco.com