



# SERFILCO®

## SERIES 'DS' DISC-SET FILTER CHAMBERS

BULLETIN  
C-305D  
FEB. 2000

### and DISC-SET FILTER MEDIA

*For filtration and purification of:*

**ETCHANTS / INSECTICIDES  
OILS / CHEMICALS / INKS  
PHOTOGRAPHIC SOLUTIONS**

**Designed for use with:  
9-disc and 16-disc Disc-Sets®  
which filter from the top and  
bottom layers of filter media.**

#### FILTER CHAMBERS

- CPVC or PVC construction with EPDM or Viton® elastomers
- Flow rates to 110 GPM (416 LPM)
- Three sizes: small, medium, large  
For: 1 to 4 of 9-disc Disc-Set, or  
1 to 3 of 16-disc Disc-Set

#### DISC-SET FILTER MEDIA

- Cellulose fiber — depth filtration
- Filtration area  
9-disc Disc-Set: **10.2 sq. ft.** (.9 sq. m)  
16-disc Disc-Set: **18.1 sq. ft.** (1.7 sq. m)
- Nominal particle retention  
2, 5, 10, 15 and 25 micron
- Buna-N elastomer



**SERIES 'DS' Filter chambers** are designed to accommodate combinations of 1 to 4 9-disc or 1 to 3 16-disc Disc-Sets by use of spacer spools which are included with each assembly. Design features top access for quick and easy Disc-Set removal and replacement while shell remains sealed to base. Capability of a single chamber to accommodate Disc-Set combinations significantly reduces operating cost and downtime. On-site selection of 180° or 90° entry to exit is an added piping convenience.

**Disc-Set Filters** constructed from individual two-sided cells of blended cellulose are assembled into a

convenient-to-use filtration system. Each Disc-Set assembly is independently sealed by an injection molding process utilizing chemically stable polypropylene. Edge seal bosses are incorporated as a special feature to prevent disc collapse during prolonged filtration runs. The cells are then assembled under predetermined compression into 9 and 16 disc configurations suitable for particle removal in the 2 to 25 micron range. Specially designed anti-rotating spacers are placed between discs which are held together by three stainless steel straps. Disc-Set end seals are Buna-N. Disc-Sets must be ordered separately.

## CHAMBER SPECIFICATIONS

A floor standing filter chamber of PVC or CPVC with EPDM or Viton gaskets and CPVC internals. Quick opening cover closure with stainless steel swing bolts with polyester 'T' handles and FRP reinforcing plate at cover and base. Top and bottom retainer brackets are stainless steel. Inlet and outlet connections are 1½" NPT with 1½" NPT influent drain plug and ¾" NPT effluent drain plug. A 0-60 PSI pressure gauge on Hypalon®

diaphragm and CPVC vent valve assembly are mounted in cover. Use of 9-disc or 16-disc Disc-Sets in single chamber is accomplished by including interchangeable spacer spools. Removable center post allows replacement of Disc-Sets via top of chamber. See "TO ORDER CHAMBER" chart for Disc-Set combinations for each size chamber. Filter media is ordered separately.

### DISC-SET MEDIA

Disc-Set filter media and the 9 and 16-disc assemblies are manufactured under strict quality control guidelines, thereby ensuring product of uniform and consistent quality. Physical treatment of the cellulose fiber structure during manufacturing, combined with the unique binder system, produces a strong media matrix that maintains wet strength and pliability and low media migration. Anti-rotating spacers are placed between discs which are held together by three stainless steel straps. Each disc offers a three function particle removal mechanism which combines surface sieving, depth entrapment with electrokinetic adsorption to provide high solids loading and efficiency. Consult Application Engineering Dept. for other particle removal densities and carbon blends.

**DISC-SET MEDIA FLOW RATE VS. PRESSURE DROP**

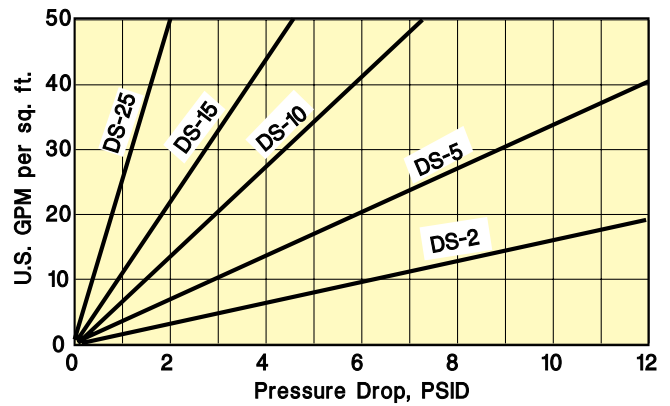

### SERIES 'DS' CHAMBER DIMENSIONS

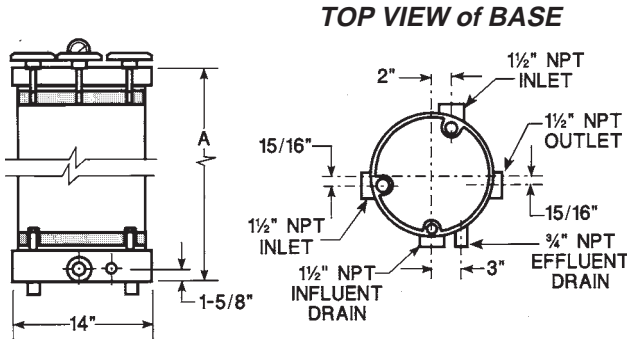

**MAX. PRESSURE AT OPERATING TEMP. W/TOP & BOTTOM REINFORCING PLATES**

TEMP.	PSI	
	PL	CL
70°F	80	80
100°F	75	75
120°F	40	70
140°F	25	55
170°F	—	35
200°F	—	30

### TO ORDER CHAMBER

MODEL	MATERIAL	HEIGHT 'A'	No. of DISC-SETS		PRICE CODE NO.
			9-disc	16-disc	
DSPL(1)S-1.5-G3A	PVC/EPDM	21-1/8"	1	1	78-1403
DSPL(2)S-1.5-GSA		33-1/8"	1, 2 or 3	1 or 2	78-1404
DSPL(3)S-1.5-GSA		42-7/8"	1, 2, 3 or 4	1, 2, or 3	78-1405
DSCL(1)S-1.5-GSA	CPVC/EPDM	21-1/8"	1	1	78-1406
DSCL(2)S-1.5-GSA		33-1/8"	1, 2 or 3	1 or 2	78-1407
DSCL(3)S-1.5-GSA		42-7/8"	1, 2, 3 or 4	1, 2 or 3	78-1408

### TO ORDER MEDIA

DISC-SET MODEL NO.	MICRON	DISC-SET	PRICE CODE NO.
DS-2C9U	2	9	78-1387
DS-5C9U	5		78-1388
DS-10C9U	10		78-1389
DS-15C9U	15		78-1390
DS-25C9U	25		78-1391
DS-2C16U	2	16	78-1392
DS-5C16U	5		78-1393
DS-10C16U	10		78-1394
DS-15C16U	15		78-1395
DS-25C16U	25		78-1396

### OPTIONAL

Viton gaskets	Change <b>L</b> to <b>V</b> in Model and add <b>V</b> to PCN
1½" flange conns.	Add <b>F</b> suffix to Model and Price Code No.
1½" BSP conns.	Add <b>B</b> suffix to Model and Price Code No.

9-disc Disc-Set packed 3 per carton.  
16-disc Disc-Set packed 2 per carton.

Registered trademarks:  
Hypalon, Viton - DuPont Dow Elastomers

F.O.B. Northbrook, Illinois

Specifications subject to change without notice.



# SERFILCO, LTD.

2900 MacArthur Blvd. 847-509-2900  
Northbrook, IL 60062-2005 U.S.A. 800-323-5431  
e-mail: sales@serfilco.com FAX: 847-559-1995  
www.serfilco.com